



OUR INTEGRATION — YOUR SUCCESS ARPAC LLC

9555 W. Irving Park Road

Schiller Park, IL 60176

Phone: 847-678-9034 • Fax: 847-671-7006

Email: info@arpac.com

Item # FP 4009, Full Pallet Turntable with Transporting Conveyor

While ARPAC's Palletizers are complete for most applications, we know that many customers have special requirements and we are ready to handle them. A wide variety of Pallet Handling and Product Handling Accessories are available to meet your specific application requirements.

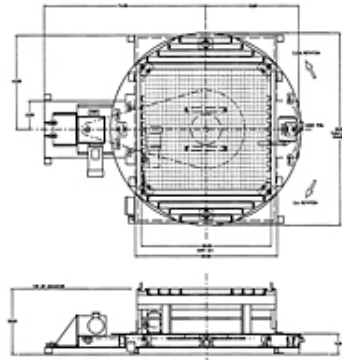
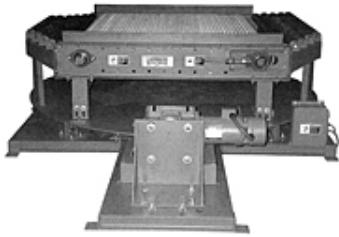

STANDARD SPECIFICATIONS

- Stand alone unit
- Rugged framework construction
- Handles palletized or unitized loads up to 56" x 56" and up to 4,000 pounds
- Turntable will accept chain driven live roller or wire mesh conveyor
- Travel speeds up to 45 FPM
- Rotation speeds up to 6 RPM
- Power requirements are 480VAC, 3Ph, 60Hz, 15A service
- All controls and control cabinet are NEMA 12