



OUR INTEGRATION — YOUR SUCCESS ARPAC LLC

9555 W. Irving Park Road

Schiller Park, IL 60176

Phone: 847-678-9034 • Fax: 847-671-7006

Email: info@arpac.com

Item # Power Series LP WNW, Low Profile Wrap-N-Weigh Turntable Automatic Stretch Wrapper

The ARPAC POWER SERIES LOW PROFILE W-N-W is a robust wrapper designed, manufactured and supported to offer trouble free operation.

The pallet lifter or forklift sets the pallet onto the turntable of the ARPAC POWER SERIES, W-N-W stretch wrapping machine. The operator then pulls the lanyard cord to begin the wrap sequence. The film is automatically attached and the EZ-LOAD® film pre-stretch module stretches the film from 150% up to 300% (200% standard). Once the pallet is wrapped, the film is automatically cut and the tail is wiped to the pallet. The pallet can now be removed from the turntable and the cycle repeated.

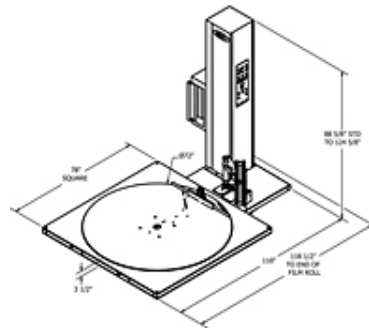

FEATURES

SYSTEM COMPONENTS (INCLUDED IN THE BASE PRICE)

- Heavy-duty, welded steel construction (no plastic panels) designed for long life
- Environmentally friendly Powder Coated paint
- Wraps loads up to 4000 lbs on 72 in. diameter (Optional Pit Ready Low Profile) turntable for pallet lifter access
- Variable turntable speed using ½ HP, 90VDC motor with ANSI 60 chain drive system
- Up to 12 RPM turntable can deliver 25-40 loads per hour (dependent on operation)

MACHINE CONTROL FEATURES

- Remote lanyard to start cycle
- Adjustable top and bottom illuminated LED wrap counters from 0-7
- Magnetic proximity switches in place of mechanical limit switches
- Cycle pause feature and turntable jog control
- Top film over wrap control feature (TOC)*
- Electronic film tension adjustment control on control panel
- Independent up and down film carriage controls with jog up/down switch
- Manual jog control for turntable
- Upgraded photo eye for automatic load height sensing of all color loads
- Micrologix 1200 PLC Control System using UL/CSA approved components

* Allows the operator to adjust the amount of film over wrap above the top of the pallet. This eliminates any slide or screwdriver adjustment of the photo eye.

FILM DELIVERY SYSTEM

- EZ-Load® film pre-stretch dispenser for 20 inch film rolls
- Anti-static film rollers with manufacturer's limited lifetime warranty
- Film pre-stretch capability from 150% to 300% stretch factor (200% standard)
- Variable carriage speed up to 21 feet per minute
- 1/3 HP, 90VDC motor with dual ANSI 40 chain lift drive
- Dancer bar variable corner compensation
- Photo electric load height sensing
- Top film over wrap control feature (TOC)*

WRAP-N-WEIGH FEATURES

- Four load cells built into the base weldment. (Not an add on part)
- Easy to read LED display with precision digital indicator and full numeric keyboard
- Four adjustable leveling pedestals
- All metal digital indicator enclosure

- RS-232 Interface connection
- Split frame construction

SYSTEM INSTALLATION

The Wrap-N-Weigh models are shipped as two pieces made up of the tower section and the turntable/scale section. After placement, a quick disconnect plug connects the two sections together.

The turntable/scale section requires that the scale pucks be assembled into the rigid mounted load cells and then the machine level adjusted to allow the scale to read correctly. After plug in, the operator manual will explain the entire system startup. The scale portion will self-calibrate during this time. Once the system is installed properly, it will function as a freestanding unit.