

MAINTENANCE GUIDE FOR THE JVS-10SLGFS, JVS-15SLGFS & JVS-20SLGFS

* Cleaning, inspecting and/or replacing parts can be done by following the procedure below.*

Read the entire procedure before taking apart the meter. Be careful when handling parts!

- 1) Remove the 4 corner hex bolts (1) and remove the flow meter from the manifold.
- 2) Remove the remaining 4 hex bolts (2) with a 5mm hex key.
 - a. Reinsert 2 of the bolts you just removed, the 2 on opposite ends work best, so that they are only holding by a few threads. While holding the upper housing firmly, tap the 2 bolts to separate the upper and lower housings (3 & 4). Do not pry or twist the housings to separate them, as this may damage internal parts of the meter.
- 3) Once the housings are separated:
 - a. Remove the gears (4) and shafts (6). Lift the gears straight up off of the shafts to avoid damaging the shafts.
 - b. Remove the o-ring (7).
 - c. Clean the gears, shafts, meter bodies, o-ring groove and shaft holes using solvent and a small brush.
 - d. Inspect the gears and shafts. The gears should spin freely on the shafts.
- 4) To reassemble the meter:
 - a. Replace the old o-ring if it is PTFE and replace it with a new one.
 - b. Reinsert the shafts into the shaft holes and reinsert the gears as well. Make sure the gears are spinning freely.
 - c. Keep the meter housings as parallel as possible during reassembly. Line up the index marks which are located on either end of the upper and lower housings.
 - d. Replace the 4 hex bolts (2) that were removed last and tighten them to approximately 15Nm (this is hand tight). Do not force the housings together as you could damage the meter. Tighten the bolts a few turns at a time, switching to another to gently secure the housing together. Over tightening will not damage the meter but the bolts can break if tightened too much.
- 5) After reassembly make sure the gears spin freely by gently blowing air into the inlet. You should be able to hear the gears spin given a moderate background noise level.
- 6) Reinsert the 4 corner hex bolts (1) and tighten to approximately 15Nm (this is hand tight).

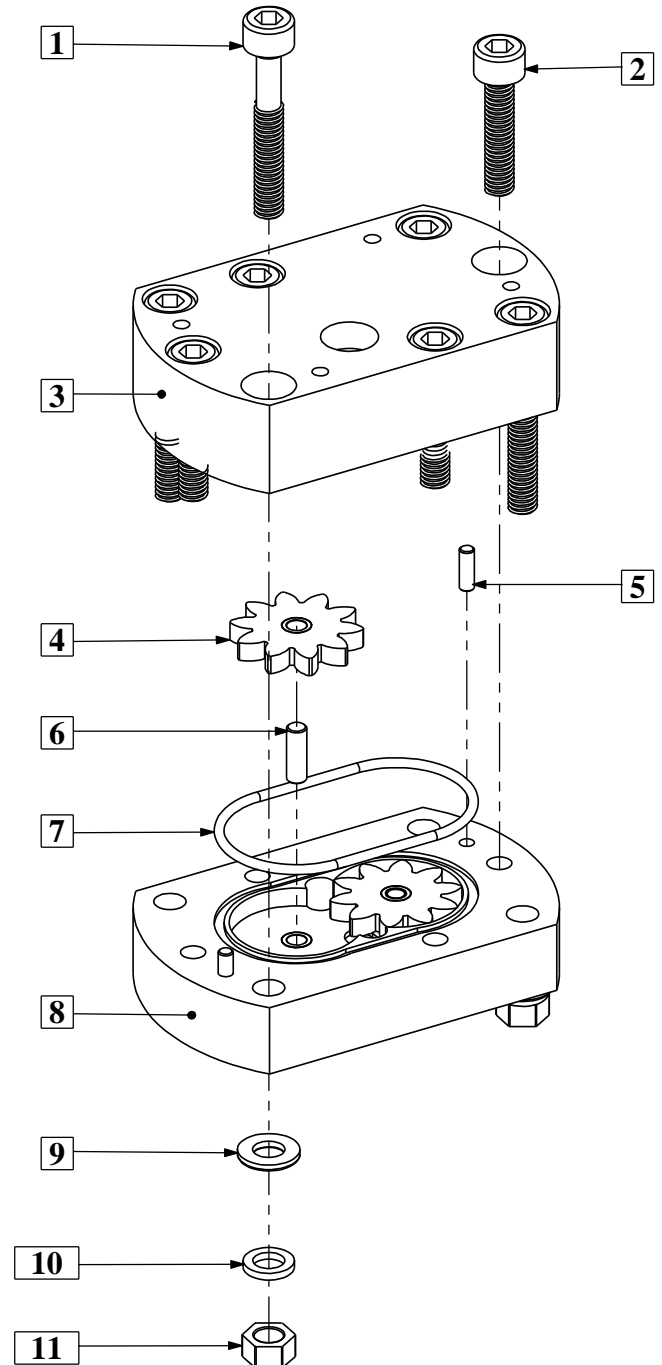

CROSS REFERENCE GUIDE FOR JVS-10SLGFS, JVS-15SLGFS & JVS-20SLGFS SERIES SPARE PARTS

Part - Qty. per meter [Drawing Ref. #]	JVS-10SLGFS	JVS-15SLGFS	JVS-20SLGFS
Upper Housing - 1 [3]	Not Field Replaceable		
Lower Housing - 1 [8]	Not Field Replaceable		
Gears - 2 [4]	AG10010 GR-10CG Gear	AG15010 GR-15CG Gear	AG20010 GR-20CG Gear
Shafts - 2 [6]	AG15052 ST-15SLGFS Shaft		AG15055 ST-20SLGFS Shaft
PTFE O-Ring - 1 [7]	AG15035 COT-10SLG	AG15050 COT-15-SLGS Teflon O-Ring	
Locating Pins - 2 [5]	AG15030 LP-CG Locating Pin		
Hex Bolts - 4 [2]	AG15070 M6 x 1.0 x 25mm		AG15060 M6 x 1.0 x 30mm
Hex Bolts - 4 [1]	SR50017 M6 x 1 x 40mm		SR50019 M6 x 1 x 45mm
Washers - 4 [9]	SR90290 M6 Stainless Steel Flat Washer		
Lock Washers - 4 [10]	SR90260 M6 stainless Steel Split Lock Washer		
Nuts - 4 [11]	SR90295 M6 Stainless Steel Nut		

Table Format: AG15010
GR-15CG Gear ← AW Part #
← AW Part Description

