



MODEL DA8



**CAUTION**

**In the event of diaphragm failure, the process fluid will mix with the loading fluid.**

**APPLICATIONS**

The “DO-ALL” design allows application of all types of clean fluids. Designed primarily for gaseous and liquid service applications where excessive cavitation is absent. Excellent for atmospheric industrial gases – GN<sub>2</sub>, GOX, Ar, He, H<sub>2</sub>, CO<sub>2</sub> – as well as a natural gas regulator. Used as a utilities – air, oil, water, steam – regulator. Non-corrosive chemical services – gas or liquid – are possible with broad materials range.

**MODEL DA8**  
**DO-ALL SERIES VIII**

**DIFFERENTIAL BACK PRESSURE  
REGULATOR**  
**Spring Operated: 1/2" – 4" (DN15 - 100)**

The Model DA8 is a differential back pressure regulators used to maintain a constant pressure differential between a fluid loading pressure ( $P_{LOAD}$ ) piped to the spring chamber and the regulator’s inlet pressure ( $P_1$ ). In the Model DA8 the  $P_1$  pressure is higher than the  $P_{LOAD}$  (Positive Bias). The amount of bias or differential pressure ( $\Delta P_{Diff}$ ) is controlled by the user adjustable setting of the range spring in the spring chamber.

The regulator uses a flow-to-open, cage balanced trim. The diaphragm is isolated from the fluid flow path by a balancing piston, which allows the user to specify either internal or external sensing of the  $P_1$  pressure.

**FEATURES**

- Versatile:** Four basic materials and multiple trim material combinations to select from.
- Tight Shutoff:** Multiple composition materials provide Class IV or VI inboard leakage rates. Designed as a soft-seated valve.
- Capacity:** Highest in the industry. Allows smaller body sizes than competitors in majority of applications.
- Pressure Drop:** Highest in the industry when coupled with high flow capacity.
- Trim Design:** “DO-ALL” trim design provides FTO and pressure balancing for higher inlet pressure. Results in unmatched sensitivity and stability. Internals are cage-contained within easily removable quick change trim.
- Rangeability:** Basic valve gives outstanding rangeability due to close tolerances, balanced trim, and a broad range of elastomeric diaphragms and soft seats. Can be as high as 1000:1.
- Heavy-Duty Guiding:** Both top and bottom guided to maintain stability and increased diaphragm life.
- Failure Position:** DA8 fails closed on loss of  $P_1$  pressure.

## STANDARD / GENERAL SPECIFICATIONS

### Body/Spring Chamber Materials

DI/DI	BRZ/BRZ *	SST/DI
CS/DI	BRZ/DI	SST/CS
CS/CS		SST/SST

\* Through 2" (DN50) body size only.  
 DI = Ductile Iron CS = Carbon Steel BRZ = Bronze  
 SST = Stainless Steel

### Body Sizes

1/2", 3/4", 1", 1-1/4", 1-1/2", 2", 3", 4"  
 (DN15, 20, 25, 32, 40, 50 80, 100)

### End Connections

Standard: Female NPT (screwed).  
 ASME Flanged: 125#, 150#, 250#, 300#, 600#;  
 DIN Flanged: PN16, PN25, PN40;  
 (Integral Flanged Body unless listed under Opt.-30)  
 Opt-31: British Standard Pipe Threads.  
 Opt-32: Schedule 80 Extended Pipe Nipples.  
 Opt-34: 14" Face to Face Flange Dimension.  
 Opt-41: Extension Tube Ends.

### Recommended Max. Useable Cv

Body Size		Diaphragm		Body Size		Diaphragm	
in	(DN)	Comp.	Metal	in	(DN)	Comp.	Metal
1/2"	(15)	3.6	3.1	2"	(50)	51	10.2
3/4"	(20)	7.2	3.1	3"	(80)	108	N/A
1"	(25)	12.7	3.1	4"	(100)	187	N/A
1-1/4"	(32)	20.7	5.0				
1-1/2"	(40)	25.5	5.0				
		<b>Cv</b>	<b>Cv</b>			<b>Cv</b>	<b>Cv</b>

See Table DAG-7 for Wide Open Cv Limits.  
 See Tables 3A through 3D and 4A through 4C for Cv vs.  
 Droop vs. Range Spring tables.

### Inlet Pressure Range

Operating: 10–750 psig (.69-51.7 Barg).  
 See Tables DAG-1A – 1F for design P vs. T limits.

### Differential Pressure Range

1/2", 3/4" & 1" (DN15, DN20 & DN25):  
 1 to 200 psid (.07 to 13.8 Bard)

1-1/4" & 1-1/2" (DN32 & DN40):  
 1 to 125 psid (.07 to 8.6 Bard)

2" (DN50):  
 1 to 90 psid (.07 to 6.2 Bard)

3" & 4" (DN80 & DN100):  
 1 to 125 psid (0.07 to 8.6 Bard)

**NOTE:** Ranges may be limited by diaphragm selection.  
 See Table 5

### Pressure Drop Limits

5 - 750 psid (0.34 to 51.7 Bard)  
 Function of service fluid, base trim material, diaphragm and  
 dynamic seal design. See Table 5 and Table DAG-2, DAG-3  
 & DAG-4.

### Temperature Range

-425° to + 400° F (-254° to + 204° C]  
 Limited by body/sp.ch. material combinations, and by  
 elastomeric – diaphragm, seat, static seal, dynamic  
 seal – materials. See Tables DAG-1A through 1F and Table  
 DAG-5.  
 Alternate "CS" Mat'l - Steel - ASTM A352 Gr. LCC - Minimum  
 temperature -50 °F (-46 °C).

### Inboard Leakage Rates

See Table DAG-10

### Optional Constructions

<p><u>Opt-30:</u> Weld-on Flanges  <u>Opt-31:</u> BSP End Conns  <u>Opt-32:</u> Ext. Pipe Nipples  <u>Opt-34:</u> 14" F to F Flange Dim.  <u>Opt-41:</u> Ext. Tube Ends  <u>Opt-55:</u> Oxygen Cleaned  <u>Opt-56:</u> Special Cleaned</p>	<p><u>Opt-57:</u> Chlorine Cleaned  <u>Opt-65:</u> Flow-ThruSp.Chmb.  <u>Opt-81:</u> Full Diaph Support  <u>Opt-85:</u> Extra Set Press Taps  <u>Opt-95:</u> Epoxy Paint  <u>Opt-95QS:</u> Epoxy Paint</p>
--------------------------------------------------------------------------------------------------------------------------------------------------------------------------------------------------------------------------------------------------------------------	--------------------------------------------------------------------------------------------------------------------------------------------------------------------------------------------------------------------------------

#### ABBREVIATIONS

FK = Fluorosilicone	NBR = Buna-N	PTFE = Polytetrafluoroethylene
FKM = Fluorocarbon	RTFE = Brz-fill TFE	V-TFE = Virgin TFE
EPR = Ethylene Propylene	GF-TFE = Glass-fill TFE	CTFE = Chlorotrifluoroethylene
BC = Neoprene	PA = PolyAll	3-ply (PTFE+FKM+PTFE)

# MATERIAL SPECIFICATIONS

## Body

- DI – ASTM A395
- CS – ASTM A216, Grade WCB.  
    Alternate ASTM A352 Gr. LCC
- BRZ – ASTM B62, Alloy 83600,
- SST – ASTM A351, Grade CF3M.

See DAG-1A through DAG-1F for material specs.

## Spring Chamber

- DI – ASTM A395
- CS – Sizes 1/2" - 2" ASTM A216 Gr. WCB;  
    Alternate ASTM A352 Gr. LCC  
    Sizes 3" & 4" ASTM A516 Gr. 55, A106 Gr. B;
- BRZ – ASTM B62, Alloy 83600.
- SST – Sizes 1/2" - 2" ASTM A351 Gr. CF3M;  
    Sizes 3" & 4" ASTM A479 Gr. 316L, A312 Gr. 316L;

## Diaphragm \*

- Elastomeric – BC, EPR, FKM, FK, NBR, FKM+TFE,  
    3-ply(PTFE+FKM+PTFE).
- Metallic – Be-Cu. (only 1/2" - 2" sizes)

## Metallic Trim \*

17-4PH SST, 316L SST, Nickel-Copper Alloy (Monel).  
See Table 2.

## Seat \*

PolyAll, V-TFE, GF-TFE, CTFE, FKM

## Static Seals (See Fig. DAG-F1) \*

- RTFE, NBR, FKM, FK, EPR, (All Sizes)
- SST/TFE (1/2" - 2") (DN15 - 50)
- V-TFE (3" - 4") (DN80 - 100)

## Dynamic Seals (See Fig. DAG-F1) \*

- Type CP – TFE cap+ NBR, FKM, EPR o-ring seal.
- Type UC – V-TFE u-cup seal with 316L SST energizer.
- Type PR – GF-TFE piston ring assembly seal with  
    17-7PH SST energizer.

## Painting

Standard: All non-corrosion resistant portions to be painted with corrosion resistant epoxy paint per Cashco Spec #S-1606.

Alternate: See Opt-95 or Opt-95OS.

\* See Product Coder for acceptable combinations  
Monel™, and Inconel® are registered trade names:  
Monel™ is a mark owned by International Nickel Co.  
Inconel® is a mark owned by International Nickel Co.

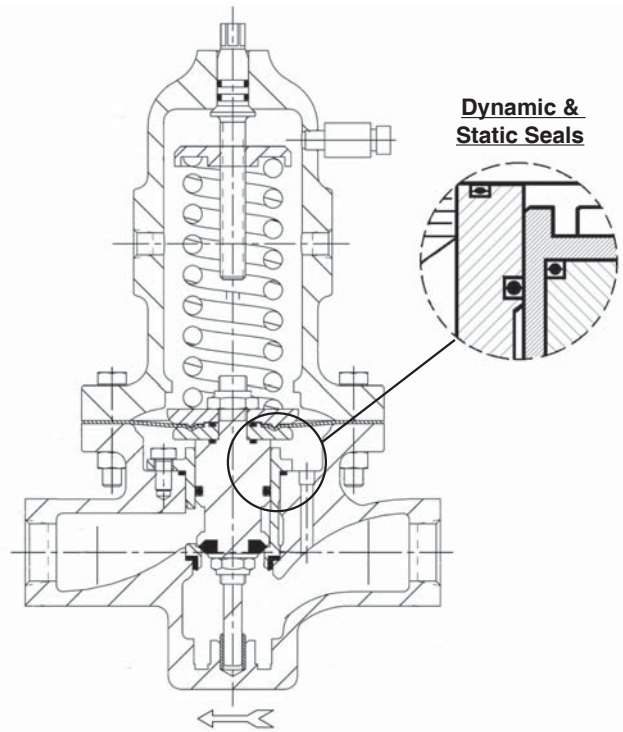

**Reverse Flow Direction Composition Diaphragm**  
**FTO – Flow-to-Open**  
**Balanced at Outlet**  
**Trim Balanced to Outlet Pressure Variations**

**FIGURE 1**

**OPTION SPECIFICATIONS**

**OPT-30:** **WELDED FLANGED CONNECTIONS.** CS, SST or HC body materials only. 1/2"-2" (DN15-50) body sizes only (no 1-1/4" (DN32) size). Welded-on flange of same general chemistry as body.

Weld-On Flanges		
Sizes	Body Material	ASME Pressure Class
1/2" - 3/4"	CS, SST	150, 300, 600
1"	CS, SST	600
Sizes	Body Material	ISO Pressure Class
DN15-50	CS, SST	PN40 RF
DN80-100	CS, SST	PN16, 25, 40 RF
^ For 1/2" - 2" sizes, CS & SST, metal diaphragm only		

**NOTES:** 1. The body P vs. T ratings are the limiting variables for flanged end connections, unless further restricted by ASME B16.5.  
2. No post-weld stress relieving performed.

**OPT-31:** **BSP END CONNECTIONS.** British Standard Pipe threads per ISO 7/1; used as an alternate to NPT ends. 1/2"-2" (DN15-50) sizes only.

**OPT-32:** **EXTENDED PIPE NIPPLES.** Sch. 80 extension pipe nipples available for CS and SST bodies; for body sizes 1/2" - 2" (DN15-50) only.

**OPT-34:** **SPECIAL 14" FACE TO FACE DIMENSION FOR FLANGED END CONNECTIONS.** Sizes 1/2" - 1" & 1-1/2" only. See Opt.-30 for standard face to face dimension.

**OPT-41:** **EXTENDED TUBE END CONN.** SST body material only. Body sizes 1/2"-1" (DN15-25), 1-1/2" & 2" (DN40-50) only. SST extension tubes are welded to body, ending in tube diameters with 0.065 inch (1.65 mm) wall thickness. **NOT FOR HIGH PURITY REQUIREMENTS.**

**OPT-55:** **SPECIAL CLEANING - GOX.** BRZ or SST body materials only. Cleaning, assembly and packaging per Cashco Spec #S-1134, making unit suitable for Oxygen Service. **NOTE: Design Pressure Rating shall not exceed 375 psig (25.8 Barg) when body/topworks material is SST and process medium is oxygen.**

**OPT-56:** **SPECIAL CLEANING.** Cleaning per Cashco Spec. #S-1542 for all body & spring chamber materials. Higher cleaning level than standard commercial cleaning. NOT suitable for Oxygen Service.

**OPT-57:** **SPECIAL CLEANING - Chlorine.** CS or SST materials only. Cleaning per Cashco Spec. #S-1589. For chlorine gas/liquid service.

**OPT-65:** **FLOW-THRU SPRING CHAMBER.** Spring chamber provided with two female NPT connections on spring chamber, allowing loading pressurizing fluid to be recirculated. Recommended for heavy oils with high paraffin content. CS spring chamber only. Tapped connection sizes dependent on body size.

**OPT-81:** **FULL DIAPHRAGM SUPPORT CONSTRUCTION.** Incorporates top & bottom diaphragm support that allows reaching higher fluid pressures on the underside and top side of diaphragm. Sizes 1/2"-2" (DN15-50) only. See Table 5.

**OPT-85:** **PRESSURE TAPS.** Provides second set of inlet and outlet 1/4" (DN8) - FNPT taps with plugs (same basic material as body) on backside of body. Includes second external sensing port tap. See page 21 for details on tap location for both STD. and Opt -85.

**OPT-95:** **EPOXY PAINT.** Special epoxy painting of all non-corrosion resistant external surfaces per Cashco Spec #S-1547. Utilized in harsh atmospheric conditions.

**OPT-95OS:** **EPOXY PAINT.** Special epoxy painting of all non-corrosion resistant external surfaces per Cashco Spec #S-1687. Utilized in OFFSHORE atmospheric conditions

**TECHNICAL SPECIFICATIONS**

**TABLE 1  
RANGE SPRINGS**

Body Size in. (DN)	Spring Range psid	Body Size in. (DN)	Spring Range psid
1/2" (15) 3/4" (20) 1" (25)	1-5* 1-10**	2" (50)	1-5* 1-10**
	5-20 10-35 20-80 30-150 70-200		5-15 10-30 15-50 30-90
1-1/4" (32) 1-1/2" (40)	1-5* 1-10**	3" (80) 4" (100)	1-10
	5-20 15-45 10-70 40-175		5-20 10-40 10-70 40-125

\* Composition diaphragm construction ONLY.  
 \*\* Metal diaphragm for set point pressure ≥ 5 psid (.34 Bard).  
 METRIC CONVERSION: psid / 14.5 = Bard

**TABLE 2  
METALLIC TRIM MATERIAL COMBINATIONS**

PART	TRIM DESIGNATION			
	S	P	M	T
Plug / Guide Bearing	316L SST	17-4 PH SST	Monel†	17-4 PH SST
Cage	316L SST	316L SST	Monel†	Monel†
Body Bushing	Monel†	17-4 PH SST	Monel†	Monel†

† See Page 3 for registered trade name information.

**TABLE 3A**  
**FULL PORT FLOW CAPACITY – Cv**  
**COMPOSITION DIAPHRAGM**  
 $F_L = 0.90$

Differential Pressure $\Delta P$ Diff (psid)	COMPOSITION DIAPHRAGM															Range Spring psid
	BODY SIZE - 1/2" (DN15)					BODY SIZE - 3/4" (DN20)					BODY SIZE - 1" (DN25)					
	10%	20%	30%	40%	50%	10%	20%	30%	40%	50%	10%	20%	30%	40%	50%	
1	1.15	1.75	2.38	2.97	3.53	1.15	1.75	2.38	2.97	3.53	1.28	2.34	3.40	4.40	5.34	1-5
3	2.67	2.77	2.91	3.03	3.16	3.44	3.95	4.85	5.70	6.50	3.83	5.27	6.93	8.49	9.95	
5	3.52	3.54	3.56	3.58	3.60	4.97	7.14	7.16	7.18	7.20	5.53	9.60	12.70	12.73	12.75	
1	0.56	0.86	1.15	1.42	1.67	0.56	0.86	1.15	1.42	1.67	0.60	1.11	1.72	2.29	2.83	1-10
5	2.64	3.54	3.56	3.58	3.60	2.80	4.90	6.50	7.18	7.20	3.66	5.10	6.67	8.15	9.54	
10	3.52	3.54	3.56	3.58	3.60	4.76	7.14	7.16	7.18	7.20	5.23	9.15	12.10	12.73	12.75	
5	2.30	3.54	3.56	3.58	3.60	2.30	4.00	5.30	6.30	7.05	2.55	4.08	5.23	6.31	7.32	5-20
10	3.52	3.54	3.56	3.58	3.60	3.64	6.40	7.16	7.18	7.20	4.04	6.59	8.67	10.60	12.50	
15	3.52	3.54	3.56	3.58	3.60	4.40	7.14	7.16	7.18	7.20	4.89	9.10	11.30	12.73	12.75	
20	3.52	3.54	3.56	3.58	3.60	6.39	7.14	7.16	7.18	7.20	7.10	12.40	12.70	12.73	12.75	
10	1.11	1.79	2.53	3.24	3.60	1.11	1.79	2.53	3.24	3.90	1.23	2.38	3.61	4.77	5.86	10-35
20	1.96	2.68	3.05	3.40	3.60	2.45	3.83	5.09	6.28	7.20	2.72	5.10	7.27	9.30	11.20	
30	3.18	3.54	3.56	3.58	3.60	3.98	5.87	7.16	7.18	7.20	4.42	7.82	10.30	12.10	12.75	
35	3.40	3.54	3.56	3.58	3.60	4.59	6.90	7.16	7.18	7.20	5.10	8.50	11.10	12.73	12.75	
20	0.84	1.40	1.94	2.44	2.91	0.84	1.40	1.94	2.44	2.91	0.94	1.87	2.76	3.60	4.39	20-80
40	1.42	2.62	3.56	3.58	3.60	1.42	2.62	3.87	5.04	6.15	1.57	3.49	5.53	7.44	9.25	
60	2.39	3.24	3.56	3.58	3.60	2.98	4.62	6.07	7.18	7.20	3.32	6.16	8.67	11.00	12.17	
80	3.33	3.54	3.56	3.58	3.60	4.17	5.50	6.50	7.18	7.20	4.63	8.10	10.70	12.60	12.75	
30	0.77	1.28	1.79	2.26	2.72	0.77	1.28	1.79	2.26	2.72	0.85	1.70	2.55	3.35	4.10	30-150
50	1.34	2.24	2.98	3.58	3.60	1.34	2.24	2.98	3.67	4.32	1.49	2.98	4.25	5.45	6.58	
75	2.30	3.51	3.56	3.58	3.60	2.30	3.51	4.58	5.59	6.53	2.55	4.68	6.55	8.30	9.96	
100	2.91	3.51	3.56	3.58	3.60	2.91	4.46	5.65	6.77	7.20	3.23	5.95	8.08	10.10	12.00	
125	3.06	3.54	3.56	3.58	3.60	3.83	5.58	6.80	7.18	7.20	4.25	7.44	9.80	11.60	12.75	
150	3.52	3.54	3.56	3.58	3.60	4.21	6.20	7.16	7.18	7.20	5.10	8.90	11.70	12.73	12.75	
70	0.58	1.44	2.32	3.15	3.60	0.58	1.44	2.32	3.15	3.93	1.00	2.00	3.00	4.00	5.00	70-200
100	1.84	3.03	3.56	3.58	3.60	1.84	3.03	4.02	4.96	5.83	2.04	4.04	5.74	7.34	8.84	
125	2.49	3.52	3.56	3.58	3.60	2.49	3.89	5.06	6.15	6.80	2.76	5.19	7.23	9.14	10.90	
150	2.91	3.54	3.56	3.58	3.60	2.91	4.59	5.53	6.42	7.20	3.23	6.12	7.91	9.58	11.20	
175	3.52	3.54	3.56	3.58	3.60	3.56	5.68	6.74	7.18	7.20	3.95	7.57	10.30	12.34	12.75	
200	3.52	3.54	3.56	3.58	3.60	4.28	7.14	7.16	7.18	7.20	4.30	7.60	10.30	12.30	12.75	

**METRIC CONVERSION FACTORS: psid / 14.5 = Bard;  $C_v / 1.16 = k_v$**

**TABLE 3B**  
**FULL PORT FLOW CAPACITY – Cv**  
**COMPOSITION DIAPHRAGM  $F_L = 0.90$**

Differential Pressure $\Delta P$ Diff (psid)	COMPOSITION DIAPHRAGM										Range Spring psid
	BODY SIZE - 1 1/4" (DN32)					BODY SIZE - 1 1/2" (DN40)					
	10%	20%	30%	40%	50%	10%	20%	30%	40%	50%	
1	1.78	2.91	3.83	4.69	5.50	1.87	3.23	4.51	5.70	6.83	1-10
5	3.91	6.67	9.27	11.70	14.00	4.12	7.40	11.00	14.30	17.50	
10	6.16	13.30	18.50	20.00	20.70	6.72	14.00	19.00	24.00	25.50	
5	2.26	4.05	5.59	7.04	8.40	2.38	4.51	6.59	8.55	10.40	5-20
10	4.85	8.67	11.50	14.10	16.60	5.10	9.69	13.50	17.10	20.50	
15	7.30	13.00	17.00	19.60	20.70	8.00	16.80	22.80	25.00	25.50	
20	9.70	17.30	20.00	20.30	20.70	10.00	18.00	24.50	25.00	25.50	15-45
15	3.79	6.89	9.10	11.20	13.10	4.00	7.65	10.70	13.60	16.30	
25	6.30	11.10	14.90	18.40	19.60	6.63	12.40	17.50	22.30	25.50	
35	8.76	15.20	19.60	19.60	0.00	9.27	16.90	23.40	25.00	25.50	10-70
45	11.40	19.80	20.00	20.30	20.70	12.80	21.00	24.50	25.00	25.50	
15	1.80	3.00	4.20	5.30	6.30	1.95	3.20	4.50	5.75	7.10	
30	3.63	6.35	8.67	10.90	12.90	3.83	7.06	10.20	13.20	15.90	40-125
50	6.26	10.70	14.00	17.10	19.60	6.59	12.00	16.60	20.90	24.90	
70	8.50	14.80	20.00	20.30	20.70	9.00	15.00	23.00	25.00	25.50	
40	2.18	4.36	5.99	7.53	8.97	2.30	4.85	7.06	9.13	11.10	40-125
50	3.23	5.66	7.58	9.39	11.10	3.40	6.29	8.93	11.40	13.70	
75	4.44	7.73	10.50	13.00	15.40	4.68	8.59	12.30	15.80	19.10	
100	5.85	9.95	13.10	16.00	18.80	6.16	11.10	15.50	19.50	23.40	
125	7.27	12.40	16.40	20.00	20.70	7.65	13.90	19.30	24.40	25.50	

**TABLE 3C**  
**FULL PORT FLOW CAPACITY – Cv**  
**COMPOSITION DIAPHRAGM  $F_L = 0.90$**

Differential Pressure $\Delta P$ Diff (psid)	COMPOSITION DIAPHRAGM					Range Spring psid
	BODY SIZE - 2" (DN50)					
	10%	20%	30%	40%	50%	
1	4.25	10.60	14.90	18.90	22.60	1-10
5	13.90	25.70	38.30	50.00	51.00	
10	22.10	41.00	49.00	50.00	51.00	
5	7.23	12.80	18.30	23.50	28.40	5-15
10	12.30	24.70	37.00	48.60	51.00	
15	19.00	36.00	49.00	50.00	51.00	
10	4.17	8.50	12.80	16.70	20.50	10-30
20	10.00	17.00	27.70	37.80	47.20	
30	15.00	25.00	38.00	50.00	51.00	
15	2.55	5.95	9.35	12.50	15.60	15-50
25	5.10	9.78	14.60	19.20	23.50	
35	7.40	15.10	22.50	29.50	36.00	
50	10.60	19.00	29.00	38.00	47.00	30-90
30	3.40	5.87	8.93	11.80	14.50	
60	6.97	12.80	18.70	24.30	29.60	
90	10.20	19.00	28.00	36.00	44.00	

METRIC CONVERSION FACTORS: psid / 14.5 = Bard;  $C_v / 1.16 = k_v$

**TABLE 3D**  
**FULL PORT FLOW CAPACITY – Cv**  
**COMPOSITION DIAPHRAGM  $F_L = 0.90$**

Differential Pressure $\Delta P$ Diff (psid)	COMPOSITION DIAPHRAGM										Range Spring psid
	BODY SIZE - 3" (DN80)					BODY SIZE - 4" (DN100)					
	10%	20%	30%	40%	50%	10%	20%	30%	40%	50%	
1	12.80	20.00	27.00	33.00	38.00	12.80	20.00	27.00	33.00	38.00	1-10
3	17.00	34.00	51.00	64.00	77.00	17.00	34.00	51.00	67.00	82.00	
5	24.70	45.10	63.00	80.00	95.00	29.80	60.00	89.00	117.00	144.00	
10	53.00	90.00	102.00	105.00	108.00	64.00	110.00	150.00	185.00	187.00	
5	20.80	36.50	52.00	70.00	83.00	25.50	42.50	61.00	79.00	95.00	5-20
10	38.00	74.00	98.00	104.00	108.00	40.80	78.00	102.00	124.00	145.00	
15	56.00	99.00	102.00	105.00	108.00	64.00	106.00	136.00	164.00	187.00	
20	77.00	100.00	102.00	105.00	108.00	85.00	150.00	180.00	184.00	187.00	
10	20.00	39.60	56.00	70.00	83.00	21.30	40.80	57.00	72.00	86.00	10-40
20	41.00	51.00	68.00	84.00	99.00	43.40	86.00	116.00	114.00	170.00	
30	56.00	74.00	96.00	102.00	108.00	60.00	108.00	145.00	179.00	187.00	
40	81.00	94.00	102.00	105.00	108.00	89.00	150.00	180.00	184.00	187.00	
10	10.30	19.80	29.50	37.70	47.00	10.50	20.00	29.80	38.00	47.00	10-70
30	22.00	43.00	63.00	81.00	95.00	23.40	45.10	66.00	86.00	105.00	
50	37.00	72.00	100.00	104.00	108.00	41.20	80.00	112.00	143.00	171.00	
70	51.00	96.00	100.00	104.00	108.00	55.00	102.00	142.00	170.00	187.00	
40	19.60	35.20	46.00	57.50	68.00	21.30	36.10	48.00	60.00	71.00	40-125
50	24.40	43.20	57.00	71.00	85.00	25.10	40.80	57.00	72.00	86.00	
75	33.00	55.00	75.00	94.50	108.00	34.00	57.00	78.00	98.00	117.00	
100	38.00	71.00	96.00	105.00	108.00	40.80	71.00	97.00	122.00	145.00	
125	47.00	89.00	102.00	105.00	108.00	48.50	90.00	126.00	158.00	186.00	

**METRIC CONVERSION FACTORS: psid / 14.5 = Bard;  $C_v / 1.16 = k_v$**



**TABLE 4A**  
**FULL PORT FLOW CAPACITY – Cv**  
**METAL DIAPHRAGM  $F_L = 0.90$**

Differential Pressure $\Delta P_{Diff}$ (psid)	Cv Capacity @ % Droop															Range Spring psid
	BODY SIZE - 1/2" (DN15)					BODY SIZE - 3/4" (DN20)					BODY SIZE - 1" (DN25)					
	10%	20%	30%	40%	50%	10%	20%	30%	40%	50%	10%	20%	30%	40%	50%	
5	1.00	1.88	2.75	2.95	3.00	1.00	1.88	2.75	2.95	3.00	1.00	1.88	2.75	2.95	3.00	5-20
10	1.60	2.80	2.85	2.95	3.00	1.60	2.80	2.85	2.95	3.00	1.60	2.80	2.85	2.95	3.00	
15	2.00	2.80	2.85	2.95	3.00	2.00	2.80	2.85	2.95	3.00	2.00	2.80	2.85	2.95	3.00	
20	2.50	2.80	2.85	2.95	3.00	2.50	2.80	2.85	2.95	3.00	2.50	2.80	2.85	2.95	3.00	
10	0.55	1.03	1.51	1.99	2.45	0.55	1.03	1.51	1.99	2.45	0.55	1.03	1.51	1.99	2.45	10-35
20	1.05	1.97	2.89	2.95	3.00	1.05	1.97	2.89	2.95	3.00	1.05	1.97	2.89	2.95	3.00	
30	1.55	2.80	2.85	2.95	3.00	1.55	2.80	2.85	2.95	3.00	1.55	2.80	2.85	2.95	3.00	
35	1.93	2.80	2.85	2.95	3.00	1.93	2.80	2.85	2.95	3.00	1.93	2.80	2.85	2.95	3.00	
20	0.40	0.75	1.10	1.44	1.78	0.40	0.75	1.10	1.44	1.78	0.40	0.75	1.10	1.44	1.78	20-80
40	0.80	1.50	2.20	2.89	3.00	0.80	1.50	2.20	2.89	3.00	0.80	1.50	2.20	2.89	3.00	
60	1.10	2.07	2.85	2.95	3.00	1.10	2.07	2.85	2.95	3.00	1.10	2.07	2.85	2.95	3.00	
80	1.50	2.80	2.85	2.95	3.00	1.50	2.80	2.85	2.95	3.00	1.50	2.80	2.85	2.95	3.00	
30	0.30	0.56	0.83	1.08	1.34	0.30	0.56	0.83	1.08	1.34	0.30	0.56	0.83	1.08	1.34	30-150
50	0.50	0.94	1.38	1.81	2.23	0.50	0.94	1.38	1.81	2.23	0.50	0.94	1.38	1.81	2.23	
75	0.70	1.32	1.93	2.53	3.00	0.70	1.32	1.93	2.53	3.00	0.70	1.32	1.93	2.53	3.00	
100	0.95	1.79	2.61	2.95	3.00	0.95	1.79	2.61	2.95	3.00	0.95	1.79	2.61	2.95	3.00	
125	1.20	2.26	2.85	2.95	3.00	1.20	2.26	2.85	2.95	3.00	1.20	2.26	2.85	2.95	3.00	
150	1.40	2.63	2.85	2.95	3.00	1.40	2.63	2.85	2.95	3.00	1.40	2.63	2.85	2.95	3.00	
70	0.50	0.94	1.38	1.81	2.23	0.50	0.94	1.38	1.81	2.23	0.50	0.94	1.38	1.81	2.23	70-200
100	0.80	1.50	2.20	2.89	3.00	0.80	1.50	2.20	2.89	3.00	0.80	1.50	2.20	2.89	3.00	
125	1.10	2.07	2.85	2.95	3.00	1.10	2.07	2.85	2.95	3.00	1.10	2.07	2.85	2.95	3.00	
150	1.30	2.44	2.85	2.95	3.00	1.30	2.44	2.85	2.95	3.00	1.30	2.44	2.85	2.95	3.00	
175	1.45	2.73	2.85	2.95	3.00	1.45	2.73	2.85	2.95	3.00	1.45	2.73	2.85	2.95	3.00	
200	1.60	2.80	2.85	2.95	3.00	1.60	2.80	2.85	2.95	3.00	1.60	2.80	2.85	2.95	3.00	

METRIC CONVERSION FACTORS: psid / 14.5 = Bard;  $C_v / 1.16 = k_v$

**TABLE 4B  
FULL PORT FLOW CAPACITY – Cv  
DA8 - METAL DIAPHRAGM  
F L = 0.90**

Differential Pressure ΔP Diff (psid)	Cv Capacity @ % Droop										Range Spring psid
	BODY SIZE - 1 1/4" (DN32)					BODY SIZE - 1 1/2" (DN40)					
	10%	20%	30%	40%	50%	10%	20%	30%	40%	50%	
5	1.30	2.44	3.43	4.25	4.87	1.30	2.44	3.43	4.25	4.87	5-20
10	2.20	4.14	4.80	4.90	5.00	2.20	4.14	4.80	4.90	5.00	
15	3.00	4.70	4.80	4.90	5.00	3.00	4.70	4.80	4.90	5.00	
20	3.75	4.70	4.80	4.90	5.00	3.75	4.70	4.80	4.90	5.00	
15	1.10	2.07	2.90	3.59	4.12	1.10	2.07	2.90	3.59	4.12	15-45
25	1.75	3.29	4.61	4.90	5.00	1.75	3.29	4.61	4.90	5.00	
35	2.40	4.51	4.80	4.90	5.00	2.40	4.51	4.80	4.90	5.00	
45	3.00	4.70	4.80	4.90	5.00	3.00	4.70	4.80	4.90	5.00	
10	1.05	1.97	2.77	3.43	3.93	1.05	1.97	2.77	3.43	3.93	10-70
30	3.02	4.70	4.80	4.90	5.00	3.02	4.70	4.80	4.90	5.00	
50	4.60	4.70	4.80	4.90	5.00	4.60	4.70	4.80	4.90	5.00	
70	4.60	4.70	4.80	4.90	5.00	4.60	4.70	4.80	4.90	5.00	
40	2.04	3.84	4.80	4.90	5.00	2.04	3.84	4.80	4.90	5.00	40-125
50	2.59	4.70	4.80	4.90	5.00	2.59	4.70	4.80	4.90	5.00	
75	4.08	4.70	4.80	4.90	5.00	4.08	4.70	4.80	4.90	5.00	
100	4.60	4.70	4.80	4.90	5.00	4.60	4.70	4.80	4.90	5.00	
125	4.60	4.70	4.80	4.90	5.00	4.60	4.70	4.80	4.90	5.00	

**METRIC CONVERSION FACTORS:**  
psid / 14.5 = Bard; C<sub>v</sub> / 1.16 = k<sub>v</sub>

**TABLE 4C  
FULL PORT FLOW CAPACITY – Cv  
DA8 - METAL DIAPHRAGM  
F L = 0.90**

Differential Pressure ΔP Diff (psid)	Cv Capacity @ % Droop					Range Spring psid
	BODY SIZE - 2" (DN50)					
	10%	20%	30%	40%	50%	
5	1.90	3.57	5.01	6.21	7.11	5-15
10	3.40	6.39	8.96	9.80	10.00	
15	5.50	9.20	9.60	9.80	10.00	
10	2.70	5.08	7.12	8.82	10.00	10-30
20	5.20	9.00	9.60	9.80	10.00	
30	7.90	9.40	9.60	9.80	10.00	
15	4.10	7.71	9.60	9.80	10.00	15-50
25	6.60	9.40	9.60	9.80	10.00	
35	9.20	9.40	9.60	9.80	10.00	
50	9.20	9.40	9.60	9.80	10.00	
30	5.10	9.40	9.60	9.80	10.00	30-90
60	9.20	9.40	9.60	9.80	10.00	
90	9.20	9.40	9.60	9.80	10.00	

**TABLE 5  
MAXIMUM DIAPHRAGM RATING \*  
psig (BARG)**

**NOTE:** The below ratings may be further "derated" by limitations thru the Pressure Equipment Directive (97/23/EC-May '97).

DIAPHRAGM MATERIAL	BODY SIZE 1/2" - 2"		BODY SIZE 3" - 4"
	STD DIAPHRAGM CONSTRUCTION	**OPT-81 FULL DIAPHRAGM SUPPORT	STD DIAPHRAGM CONSTRUCTION
	P <sub>1</sub> MAX	P <sub>1</sub> MAX	P <sub>1</sub> MAX
BC, EPR	1250 (86.1)	1250 (86.1)	800 (55.1)
NBR	450 (31.0)	1250 (86.1)	300 (20.6)
FKM, FKM+TFE, FK	700 (48.2)	1250 (86.1)	550 (37.9)
3-ply (PTFE+FKM+PTFE) ***	125 (8.6)	125 (8.6)	125 (8.6)
METAL Be-Cu	1500 (103)	NA	NA

\*Maximum setting of pressure safety device – safety relief valve or rupture disc.

\*\* Not Available for DI/DI, BRZ/DI, BRZ/BRZ,CS/DI & SST/DI construction.

\*\*\* For Steam applications.

NA = Not Available

**DAG TECHNICAL APPENDIX INDEX**

<u>TABLE</u>	<u>TITLE</u>	<u>PAGE</u>
DAG-1A .....	DI – Press vs Temp vs End Conn Ratings .....	12
DAG-1B .....	BRZ – Press vs Temp vs End Conn Ratings .....	13
DAG-1D .....	CS – Design Inlet/Outlet - DA8 .....	14
DAG-1F.....	SST – Design Inlet/Outlet - DA8.....	14
DAG-2.....	Max Pressure Drop - Comp Seat .....	15
DAG-3.....	Max Pressure Drop - Dynamic Seal Design.....	15
DAG-4.....	Max Pressure Drop - Basic Trim Mat'ls.....	15
DAG-5.....	Temperature Limits – Elastomer Mat'ls.....	16
DAG-7.....	Back Pressure Max Capacity - Plug Wide Open.....	17
DAG-10.....	Inboard Leakage Ratings .....	17
DAG-12.....	Back Press Recommended Velocity Limits.....	17
DAG-14.....	Recommended Internal Materials - Liquids.....	18
DAG-14.....	Recommended Internal Materials - Gases.....	18
DAG-14.....	Supplement - Chemical Resistance .....	19

<u>FIGURE</u>	<u>TITLE</u>	<u>PAGE</u>
DAG-F1.....	Dynamic/Static Seals .....	20
DAG-F2.....	Location of Body/Spring Chamber Taps .....	21

**TABLE DAG-1A**  
**DI – DUCTILE IRON**  
**BODY / TOPWORKS MATERIAL SPECIFICATIONS**  
**DESIGN PRESSURE vs. TEMPERATURE vs. END CONNECTION RATINGS**  
**(To ASME B16.1 for Flanged and B16.4 for NPT Connections per Cast Iron Rating)**

Material Specifications (Body / Topworks)		End Connection – Inlet & Outlet					
Description (Abbr.)	ASTM No.	Temperature °F	Working Pressure – psig				
			End Connection – Pressure Class				
			NPT	125# FF	250# RF		
DI/DI (Note 1)	A395/ A395	-20° to +150°	400	200	500		
		200°	370	190	460		
		225°	355	180	440		
		250°	340	175	415		
		300°	310	165	375		
		350°	300	150	335		
		400°	250	140	290		
		406°	250	140	290		
			400 WOG, 250 S	225 WOG, 125 S	400 WOG, 250 S		
				Temperature °C	Working Pressure – Barg		
					End Connection – Pressure Class		
					NPT	125# FF	250# RF
				-29° to +65°	27.6	13.8	34 .5
				107	24.5	12.5	30.2
				120°	23.4	12.1	28.7
		150°	21.2	11.2	25.7		
		177°	19.2	10.6	23.8		
		204°	17.5	9.6	20.3		

**NOTE 1:** Whenever body and topworks materials are mixed, the P vs. T ratings that should be applied are those which are lowest of the two materials.

**Example:** CS body, DI topworks; NPT end connections, 200°F temperature.

Because the topworks is not “end flanged”, use the DI limits of “400 PSIG CWP 370/200F” from above to compare to CS limits from DAG-1C values. The DI limits are lower, so ratings from DAG-1A MUST be used as the limits.

**NOTE 2:** Unless stated otherwise, design pressure is Maximum Allowable Working Pressure (MAWP) for Inlet and Outlet.

**TABLE DAG-1B  
BRZ – BRONZE  
BODY / TOPWORKS MATERIAL SPECIFICATIONS**

**DESIGN PRESSURE vs. TEMPERATURE vs. END CONNECTION RATINGS  
(Per ASME B16.24 for Flanged and B16.15 for NPT Connections)**

Material Specifications (Body / Topworks)		End Connection – Inlet & Outlet (Note 2)				
Description (Abbr.)	ASTM No.	Temperature °F	Working Pressure –psig			
			End Connection – Pressure Class			
			NPT	150# FF	300# FF	
BRZ/BRZ (Note 1)	B62, Alloy C83600/B62, Alloy C83600	-325° to +150° *	500	225	500	
		175°	390	220	480	
		200°	385	210	465	
		225°	375	205	445	
		250°	365	195	425	
		300°	335	180	390	
		350°	300	165	350	
		400°	250	150	315	
		406°	250	150	315	
		Temperature °C	Working Pressure – Barg			
			End Connection – Pressure Class			
			NPT	150# FF	300# FF	
			-198° to +65° *	34.5	15.5	34.5
			107°	25.8	14.0	30.8
			120°	25.1	13.5	29.5
			150°	23.0	12.4	26.8
			177°	20.4	11.3	24.0
			204°	17.8	10.3	21.4

**NOTE 1:** Whenever body and topworks materials are mixed, the P vs. T ratings that should be applied are those which are lowest of the two materials.

**Example:** BRZ body, DI topworks; NPT end connections, ambient temperature.  
Because the topworks is not “end flanged”, use the DI limits of “400 PSIG CWP 370/200F” from DAG-1A to compare to above DAG-1B values. The DI limits are lower, so ratings from DAG-1A MUST be used as the limits.

**NOTE 2:** Unless stated otherwise, design pressure is Maximum Allowable Working Pressure (MAWP) for Inlet and Outlet.

\* See Minimum Temperature Ratings Table below.

**DESIGN PRESSURE RATING  
AT MIN. TEMPERATURE**

Regulator Function	Material Specifications (Body / Topworks - Connections) Description (Abbr.)	Pressure at Min. Temperature
Back Pressure Relief	BRZ/BRZ	Inlet - 500 psig CWP to -325°F (-198°C)
		Outlet - 500 psig CWP to -325°F (-198°C)
	SST/SST - NPT, BSP, Ext. Nipples, Tube Ends and 600# Flgs	Inlet - 625 psig CWP to -425°F (-254°C)
		Outlet - 625 psig CWP to -425°F (-254°C)

**Body Material Specifications**

**Cast Steel** A216 Gr.WCB or Steel Weldment A216 Gr. WCB w/ forged flanges A105

**Alternate Material:** Cast Steel A352 Gr. LCC or Steel Weldment A352 Gr. LCC w/ forged flanges A350 Gr. LF6 Class 2

**Topworks Material Specifications**

**Cast Steel** A216 Gr. WCB or Steel Weldment A516 Gr. 55 & A105

**Alternate Material:** Cast Steel A352 Gr. LCC

**DESIGN PRESSURE vs. TEMPERATURE vs. END CONNECTION RATINGS**

(Per ASME B16.5 and B16.34) See NOTE 1

TABLE DAG-1D DESIGN PRESSURE (BOTH INLET AND OUTLET) FOR DA8 in PSIG (BARG)				
CONSTRUCTION	END CONNECTIONS			
	STD DIAPHRAGM	ALL		Opt-81 (Full Support Diaph.) DA8
DESIGN TEMP. RANGE: Deg F (Deg C) **	NPT, BSP, 600#, EXTD NIPP	150#	300#	NPT, BSP. 600#, EXTD NIPP
-20 to +100 (-29 to +38)	750 (51.7)	285 (19.6)	740 (51.1)	1350 (93.0)
-20 to +200 (-29 to +93)	680 (47.1)	260 (17.9)	680 (47.1)	1350 (93.0)
-20 to +300 (-29 to +149)	655 (45.1)	230 (15.8)	655 (45.1)	1310 (90.3)
-20 to +400 (-29 to +204)	635 (43.6)	200 (13.7)	635 (43.8)	1265 (87.3)

\*\* Alternate Mat'l: ASTM 352 Gr. LCC Min. Temperature -50 °F(-46°C).

**Cast Stainless Steel** A351 Gr.CF3M or Stainless Steel Weldment A315 Gr. CF3M w/ forged flanges A182 Gr. F 316L

**Topworks Material Specifications**

**Cast Stainless Steel** A351 Gr.CF3M or Stainless Steel Weldment A312 Gr. 316/316L, A479 Gr. 316/316L

**DESIGN PRESSURE vs. TEMPERATURE vs. END CONNECTION RATINGS**

(Per ASME B16.5 and B16.34) See NOTE 1 using SST specifications; & NOTE 2

TABLE DAG-1F DESIGN PRESSURE (BOTH INLET AND OUTLET) FOR DA8 in PSIG (BARG)				
CONSTRUCTION *	END CONNECTIONS			
	STD DIAPHRAGM	ALL		Opt-81 (Full Support Diaph.) DA8
DESIGN TEMP. RANGE: Deg F (Deg C)	NPT, BSP, 600#, EXTD NIPP, TUBE	150#	300#	NPT, BSP. 600#, EXTD NIPP, TUBE
-425 to +100 (-254 to +38)	625 (43.0)	275 (19.0)	625 (43.0)	1125 (77.5)
-20 to +200 (-29 to +93)	620 (42.3)	235 (16.5)	620 (42.3)	1125 (77.5)
-20 to +300 (-29 to +149)	560 (38.6)	215 (14.8)	560 (38.6)	1120 (77.0)
-20 to +400 (-29 to +204)	515 (35.5)	195 (13.6)	515 (35.5)	1025 (70.9)

**NOTE 1:** These pressure ratings may be further derated by limitations thru the Pressure Equipment Directive (97/23/EC-May '97). Whenever body and topworks are mixed, the P vs. T ratings that should be applied are those which are lowest for the two materials.

**Example:** 600 lb. RF flanged **steel** body at 200 deg F maximum temp would have a preliminary inlet to 680 psig, but if fitted with a **ductile iron** topworks pressure rating is only 370 psig. Must derate both the inlet and outlet to 370 psig. (Note: Topworks pressure rating, same as NPT design outlet pressure rating for the selected topworks material and diaphragm type.)

**NOTE 2:** Maximum Design Pressure Rating for 2" Opt -41 limited by 0.065" wall thickness to 1200 psig.

300# Flanges are derated due to the bolting for these products.

**TABLE DAG-2  
MAXIMUM PRESSURE DROP FOR  
COMPOSITION SEATS**

Body Size		Max. Pressure Drop - psid (Bard)											
		Seat Material											
in	(DN)	POLYALL *						GF-TFE					
		Liquid *		Gas		Steam	Liquid *		Gas		Steam √		
1/2" – 1"	(15-25)	600	(41.3)	750	(51.7)	DNA	450	(31.0)	1000	(68.9)	150/125	(10.3/8.6)	
1-1/4" – 1-1/2"	(32-40)	600	(41.3)	600	(41.3)	DNA	450	(31.0)	900	(62.0)	150/125	(10.3/8.6)	
2"	(50)	600	(41.3)	600	(41.3)	DNA	450	(31.0)	750	(51.7)	150/125	(10.3/8.6)	
3" – 4"	(80-100)	500	(34.4)	600	(41.3)	DNA	450	(31.0)	750	(51.7)	125	(8.6)	
		V-TFE						CTFE					
1/2" – 1"	(15-25)	300	(20.7)	600	(41.3)	125	(8.6)	600	(41.3)	3000	(206.9)	DNA	
1-1/4" – 1-1/2"	(32-40)	300	(20.7)	600	(41.3)	125	(8.6)	600	(41.3)	3000	(206.9)	DNA	
2"	(50)	300	(20.7)	600	(41.3)	125	(8.6)	600	(41.3)	2000	(137.9)	DNA	
3" – 4"	(80-100)	300	(20.7)	450	(31.0)	125	(8.6)	500	(34.4)	1500	(103.4)	DNA	

\* Only seat material to be applied in liquid "partially cavitating" service is PolyAll.  
√ Steam Service: metal diaphragm/composition diaphragm.  
N/A = Not Available  
DNA = Do Not Apply

**TABLE DAG-3  
MAXIMUM PRESSURE DROP FOR  
DYNAMIC SEAL DESIGNS**

Body Size		Max. Pressure Drop - psid (Bard)																	
		Dynamic Seal Design																	
in	(DN)	"OR" – O-RING *						"CP" – TFE CAP						"CW" – TFE CAP w/WIPER					
		Liquid *		Gas *		Steam	Liquid		Gas		Steam	Liquid		Gas		Steam			
1/2" – 1"	(15-25)	600	(41.3)	750	(51.7)	DNA	600	(41.3)	600	(41.3)	DNA	450	(31.0)	600	(41.3)	DNA			
1-1/4" – 1-1/2"	(32-40)	600	(41.3)	750	(51.7)	DNA	600	(41.3)	600	(41.3)	DNA	450	(31.0)	600	(41.3)	DNA			
2"	(50)	600	(41.3)	750	(51.7)	DNA	600	(41.3)	600	(41.3)	DNA	450	(31.0)	600	(41.3)	DNA			
3" – 4"	(80-100)	600	(41.3)	750	(51.7)	DNA	600	(41.3)	600	(41.3)	DNA	450	(31.0)	600	(41.3)	DNA			
		"PR" – PISTON RING ASSY.						"PW" – PISTON RING ASSY. w/WIPER						"UC" – U-CUP					
1/2" – 1"	(15-25)	DNA	DNA	150/125	(10.3/8.6)	DNA	DNA	150/125	(10.3/8.6)	600	(41.3)	3000	(206.9)	DNA					
1-1/4" – 1-1/2"	(32-40)	DNA	DNA	150/125	(10.3/8.6)	DNA	DNA	150/125	(10.3/8.6)	600	(41.3)	3000	(206.9)	DNA					
2"	(50)	DNA	DNA	150/125	(10.3/8.6)	DNA	DNA	150/125	(10.3/8.6)	600	(41.3)	3000	(206.9)	DNA					
3" – 4"	(80-100)	DNA	DNA	125	(8.6)	DNA	DNA	125	(8.6)	600	(41.3)	3000	(206.9)	DNA					

\* Only seat material to be applied in liquid "partially cavitating" or "flashing" service is PolyAll.  
√ Steam Service: metal diaphragm/composition diaphragm.  
N/A = Not Available    DNA = Do Not Apply    wo/ = without    w/ = with

**TABLE DAG-4  
MAXIMUM PRESSURE DROP FOR  
BASIC TRIM MATERIAL**

Body Size		Max Pressure Drop - psid (Bard)							
		Basic Trim Material							
in	(DN)	"P" – 17-4PH SST		"S" – 316L SST		"M" – Monel		"T" – Hybrid *	
1/2" – 2"	(15-50)	3000	(206.9)	800	(55.1)	1500	(103.4)	3000	(206.9)
3" – 4"	(80-100)	3000	(206.9)	800	(55.1)	1500	(103.4)	3000	(206.9)

\* 17-4PH SST plug & piston, Monel cage.

**TABLE DAG-5  
TEMPERATURE LIMITS  
FOR ELASTOMERIC MATERIALS**

Elastomer			T Maximum		T Minimum	
Seals	ID	Description	°F	(°C)	°F	(°C)
	Seats	PolyAll	Proprietary Polyurethane Derivative	225°	(107°)	-60°
GF-TFE		Glass-filled Polytetrafluorethylene	425°	(218°)	-325°	(-198°)
V-TFE		Virgin TFE	400°	(205°)	-325°	(-198°)
CTFE		Chlorotrifluoroethylene TFE	300°	(148°)	-325°	(-198°)
FKM		Fluorocarbon Elastomer	400°	(205°)	0°	(-17°)
Diaphragms	3-Ply	3-Ply TFE/FKM/TFE	400°	(205°)	0°	(-17°)
	BC	Neoprene (Polychloroprene)	250°	(121°)	-65°	(-53°)
	EPR	Ethylene Propylene	300°	(148°)	-40°	(-40°)
	FK	Fluorosilicone	350°	(177°)	-65°	(-54°)
	FKM	Fluorocarbon Elastomer	400°	(205°)	0°	(-17°)
	NBR	Buna-N (Nitrile)	250°	(121°)	-70°	(-56°)
	FKM+TFE	Fluorocarbon Elastomer + TFE	400°	(205°)	0°	(-17°)
Static Seals	RTFE	Bronze-filled TFE	425°	(218°)	70°	(21°)
	V-TFE	Virgin TFE	400°	(205°)	-325°	(-198°)
	EPR	Ethylene Propylene	300°	(148°)	-40°	(-40°)
	FK	Fluorosilicone	350°	(177°)	-65°	(-54°)
	FKM	Fluorocarbon Elastomer	400°	(205°)	-20°	(-28°)
	NBR	Buna-N	212°	(100°)	-40°	(-40°)
	SST/TFE	301/302 SST U-cup / TFE	400°	(205°)	-325°	(-198°)
	HC/TFE	Hastelloy C U-cup / TFE	400°	(205°)	-325°	(-198°)
Dynamic Seals	"PR"	Piston Ring Assy, GF-TFE / SST	425°	(218°)	-40°	(-40°)
	"PW"	PRA* w/Wiper, GF-TFE / SST / GF-TFE	425°	(218°)	70°	(21°)
	"CW" – EPR/TFE	TFE Cap Seal, EPR O-ring, GF-TFE Wiper	300°	(148°)	-40°	(-40°)
	"CW" – NBR/TFE	TFE Cap Seal, NBR O-ring, GF-TFE Wiper	212°	(100°)	-40°	(-40°)
	"CW" – FK/TFE	TFE Cap Seal, FK O-ring, GF-TFE Wiper	350°	(177°)	-40°	(-40°)
	"CW" – FKM/TFE	TFE Cap Seal, FKM O-ring, GF-TFE Wiper	400°	(205°)	-20°	(-28°)
	"CP" – EPR/TFE	TFE Cap Seal, EPR O-ring	300°	(148°)	-40°	(-40°)
	"CP" – NBR/TFE	TFE Cap Seal, NBR O-ring	212°	(100°)	-40°	(-40°)
	"CP" – FK/TFE	TFE Cap Seal, FK O-ring	350°	(177°)	-10°	(-23°)
	"CP" – FKM/TFE	TFE Cap Seal, FKM O-ring	400°	(205°)	-20°	(-28°)
	SST/TFE	301/302 SST U-cup / TFE	400°	(205°)	-325°	(-198°)
	HC/TFE	Hastelloy C U-cup / TFE	400°	(205°)	-325°	(-198°)
	ELG/TFE	Elgiloy / TFE U-cup	400°	(205°)	-325°	(-198°)

\* PRA - Piston Ring Assembly

Metal Diaphragm		T Maximum		T Minimum	
ID	Description	°F	(°C)	°F	(°C)
BE-CU	Beryllium Copper	400°	(205°)	-325°	(-198°)

ABBREVIATIONS			
FK = Fluorosilicone	NBR = Buna-N	PTFE = Polytetrafluoroethylene	PRA = GF-TFE/SST
FKM = Fluorocarbon Elastomer	RTFE = Brz-fill TFE	V-TFE = Virgin TFE	BC = Neoprene
EPR = Ethylene Propylene	GF-TFE = Glass-fill TFE	CTFE = Chlorotrifluoroethylene TFE	ELG = Elgiloy



**TABLE DAG-7  
BACK PRESSURE MAXIMUM CAPACITY WITH PLUG WIDE-OPEN**

Body Size		Full Port Max Capacity		Full Port Max Capacity	
in	(DN)	Cv	Kv	Cv	Kv
1/2"	(15)	4.0	2.9	3.0	2.6
3/4"	(20)	8.0	5.9	3.0	2.6
1"	(25)	12.8	11.0	3.0	2.6
1-1/4"	(32)	23	20	5.1	4.4
1-1/2"	(40)	26	22	5.1	4.4
2"	(50)	51	44	10.2	8.8
3"	(80)	120	104	X	
4"	(100)	187	161		
<b>Diaphragm</b>		<b>Composition</b>		<b>Metal</b>	

**NOTE:** The above Cv factors may be used for sizing of safety relief valves or rupture discs.

**TABLE DAG-10  
INBOARD LEAKAGE RATINGS \*  
Per ANSI/FCI 70-2**

Seat Material	Dynamic Seal	
	O-Ring	Dynamic Seals Except O-Ring
CTFE, GF-TFE, and V-TFE	IV	IV
PolyAll, FKM	VI	IV

\*Inboard leak rates are the composite leakage of the seat leakage + dynamic seal leakage, considered as a single inboard leakage value.

**TABLE DAG-12  
BACK PRESSURE RECOMMENDED VELOCITY LIMITS**

Application Fluid	Valve Type	Valve Size Range		Upstream Pipe		Valve Body Inlet (1-Phase)		Valve Body Outlet	Downstream Pipe	Units
		in	(DN)	Recommend	Max.	Recommend	Max.			
		Liquid	BPV	1/2"-4"	(15-100)	5-8	16			
6"	(150)			7-12	20	15	24			
8"-12"	(200-300)			9-14	24	-	-			
Gas	BPV	1/2"-1"	(15-25)	0.15	0.30	0.15	0.25	<1.00	<0.8	Mach #
		1-1/4"-2"	(32-50)	0.20	0.30	0.20	0.30			
		2-1/2"-6"	(65-150)	0.22	0.30	0.25	0.35			
Steam	BPV	1/2"-1"	(15-25)	0.10	0.30	0.20	0.30	<0.8	<0.65	Mach #
		1-1/4"-2"	(32-50)	0.12		0.22				
		2-1/2"-6"	(65-150)	0.15		0.25				
Steam	BPV	8"-12"	(200-300)	0.20	0.30	-	-	<0.8	<0.65	Mach #

**NOTES:**

- Liquids experiencing no 2-phase flow at valve outlet will have same valve body outlet velocity as inlet velocity.
- Liquids experiencing 2-phase flow at valve outlet should have average velocity less than 150-200 ft/sec.
- Liquids experiencing 2-phase flow at outlet pipe should have average velocity less than 20-50 ft/sec.
- If valve outlet exceeds recommended limits, then can use external sensing to reach maximum limits.
- On gas service, a pilot operated prv can work with a outlet Mach = 0.75.

**TABLE DAG-14**  
**RECOMMENDED INTERNAL MATERIALS**  
**For P<sub>max</sub>, Reference Individual Technical Bulletins**

	LIQUIDS			
	Fluid	Tmax °F	Tmin °F	Metal Trim
LIQUIDS	<b>Industrial Water – Cold</b>	180°	32°	P2
	Hot	225°	32°	PJ
	DI, DM	225°	32°	PJ
		250°	32°	PL
	Seawater	180°	-20°	MH
	<b>Fuel Oils – Diesel, #1, #2‡</b>	180°	-40°	P6
	Bunker C, #3 - #6‡	180°	-40°	P6
		400°	0°	PD
	Jet Fuel JP3, JP4, JP5, JP6‡	400°	0°	PD
	Kerosene‡	400°	0°	PD
<b>Crude Oils – Sweet‡</b>	225°	0°	PB	
	400°	0°	PD	
Sour‡	225°	0°	CF *	
<b>Heat Transfer Oils – Dowtherm, Therminol, Mobil-Therm, Silvatherm</b>	400°	0°	PD	
LIQUIDS	<b>Misc. Oils – Lube Oil‡</b>	180°	-40°	P6
	Naptha‡	400°	0°	PD
	Turbine Oil‡	225°	0°	PB
	<b>Edible Oils – Vegetable Oil‡</b>	180°	-30°	PH
	Animal Fats‡	180°	-30°	PH
	Seed Oils‡	180°	-30°	PH
	<b>Inorganic Acids – Acetic - 5%</b>	100°	0°	SL
	Acetic - 30%	100°	0°	SL
	Sulfuric - conc.	100°	0°	CF *
	Sulfuric - dilute	100°	0°	CF *
Nitric - conc.	140°	0°	SL	
Nitric - dilute	140°	0°	SL	
Hydrofluoric (air free) - dilute, concentrate	100°	0°	CF *	
Hydrobromic	140°	0°	CF *	
Phosphoric - dilute, concentrate	150°	0°	SL	
LIQUIDS	<b>Misc. Liquids – Gasoline‡</b>	150°	-40°	P6
	Benzene (C <sub>6</sub> H <sub>6</sub> )‡	150°	0°	SL
	Chlorine (Cl <sub>2</sub> )	150°	0°	ML
	Bromine (Br <sub>2</sub> )	150°	0°	CF *
	Ammonia (NH <sub>3</sub> )	140°	0°	SL
	Hydrogen Peroxide (H <sub>2</sub> O <sub>2</sub> )	125°	0°	SL
	Hydrogen Chloride (HCl)	125°	0°	ML
	Hydrogen Bromide (HBr)	125°	0°	SL
	Cane Sugar Liquor	180°	0°	PH

‡ In accordance with ASME B31.3 "Process Piping", do not use Ductile Iron Body for hydrocarbon or flammable service with inlet pressures greater than 150 psig (10.3 Barg) or temperatures greater than 300 deg F (149 deg C).  
 \* CF = Consult Factory

	GASES			
	Fluid	Tmax °F	Tmin °F	Trim
Atmospheric Gases	<b>Atmospheric Gases – O<sub>2</sub> (GOX)</b>	225°	-60°	M7
		350°	-65°	M9
		350°	-325°	TN
	N <sub>2</sub> (GN <sub>2</sub> ), Air, Argon	180°	-60°	P2
		350°	-65°	P8
	CO <sub>2</sub> (dry)	180°	-40°	P6
CO <sub>2</sub> (wet)	180°	-40°	P6	
Process Gases	<b>Process Gases – Nat. Gas (Sweet)</b>	180°	-65°	P9
	Nat. Gas (Sour)	180°	-40°	CF *
	LPG (propane)	180°	-40°	PH
	Ammonia	120°	-40°	CF *
	Hydrogen	180°	-325°	SN
	Helium	180°	-325°	SN
	Chlorine (dry)	200°	0°	ME
	Hydrogen Chloride (dry)	120°	-40°	SJ
	Hydrogen Bromide (dry)	120°	0°	PE
	Hydrogen Fluoride (dry)	120°	0°	PE
	Hydrogen Sulfide (dry)	140°	0°	CF *
	Hydrogen Sulfide (wet)	140°	0°	CF *
Sulfur Dioxide (dry)	120°	0°	PE	
STEAM	P1 ≤ 125 psig	350°	—	PG

## **DAG-14 SUPPLEMENT CHEMICAL RESISTANCE**

**General Statement:** Statements located within this technical bulletin concerning suitability of fluids with TFE materials are general statements, and should not be construed as recommendations. Any statements of suitability are the result of a compilation of various sources of information based on experience, tests, and published technical literature. No guarantee or warranty is in anyway implied for a given particular service or application.

**Additional Reference:** For an inclusive listing covering a broader range of service application fluids, reference "Handbook of Corrosion Resistant Piping", P.A. Schweitzer, Industrial Press or "Compass Corrosion Guide", 2nd Edition, K.M. Pruett, Compass Publications. This publication will include information based on the following fluid variables:

1. Solution concentration
2. Pressure
3. Temperature

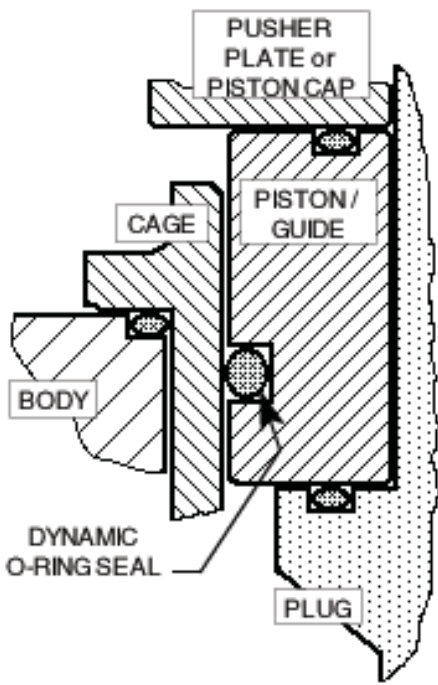

O-RING DYNAMIC SEAL

PRV, BPV

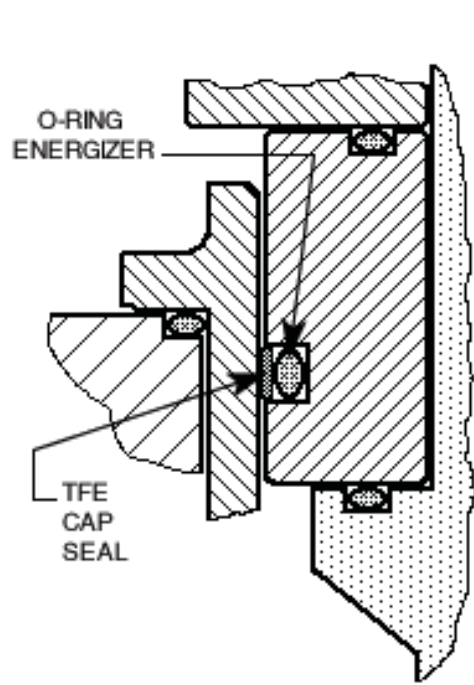

TFE CAP DYNAMIC SEAL

BPV

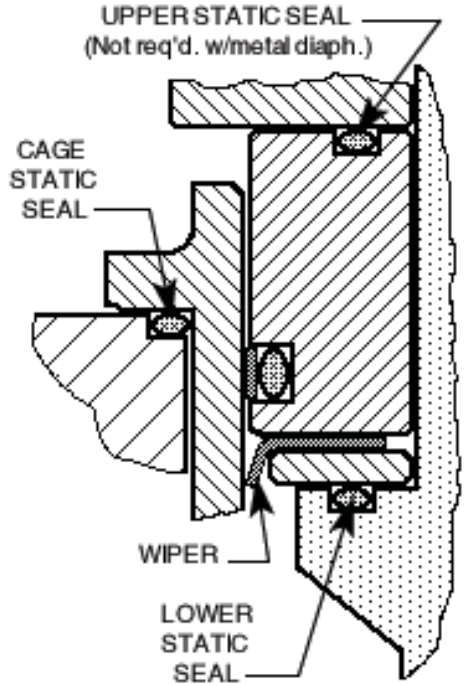

TFE CAP DYNAMIC SEAL + WIPER

PRV

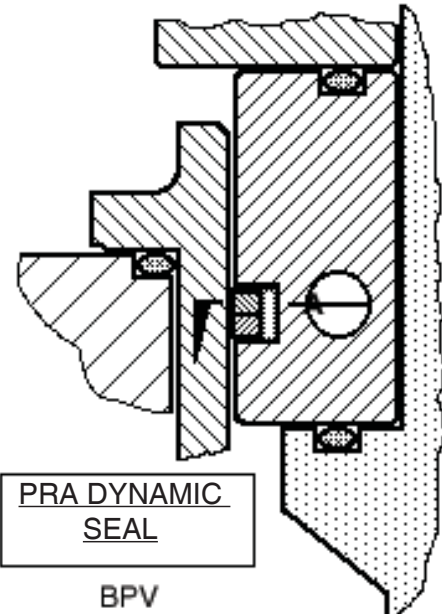

PRA DYNAMIC SEAL

BPV

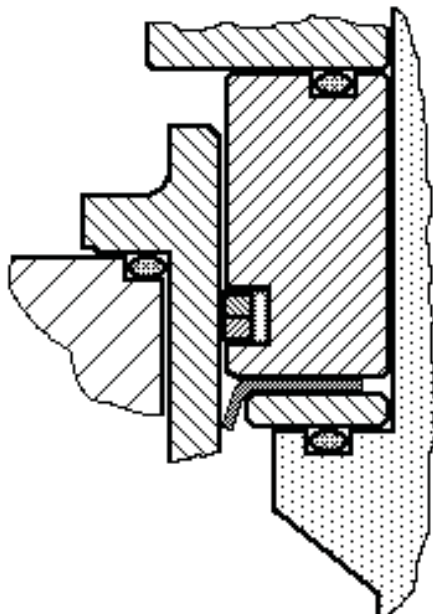

PRA DYNAMIC SEAL + WIPER

PRV

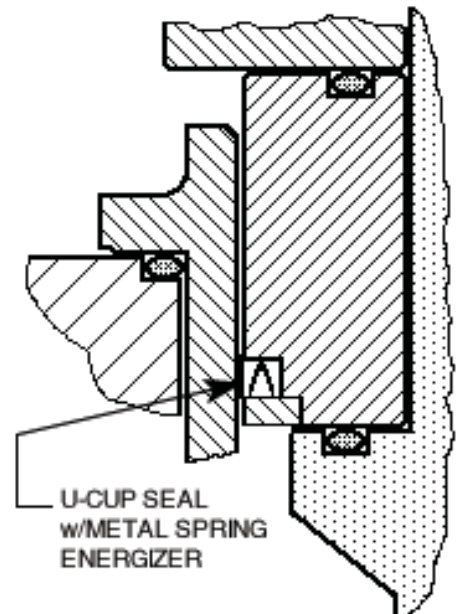

U-CUP SEAL w/METAL SPRING ENERGIZER

U-CUP DYNAMIC SEAL

PRV, BPV

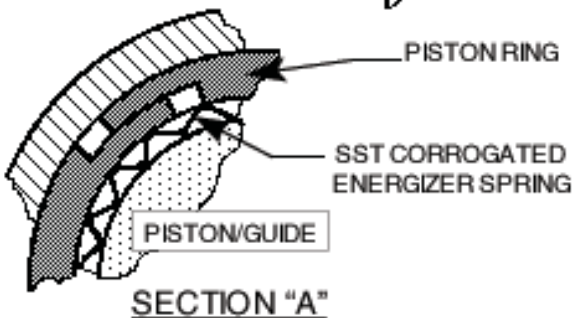

SECTION "A"

FIGURE DAG-F1  
DYNAMIC & STATIC SEALS

**FIGURE DAG-F2**  
**Location of BODY / SPRING CHAMBER TAPS**

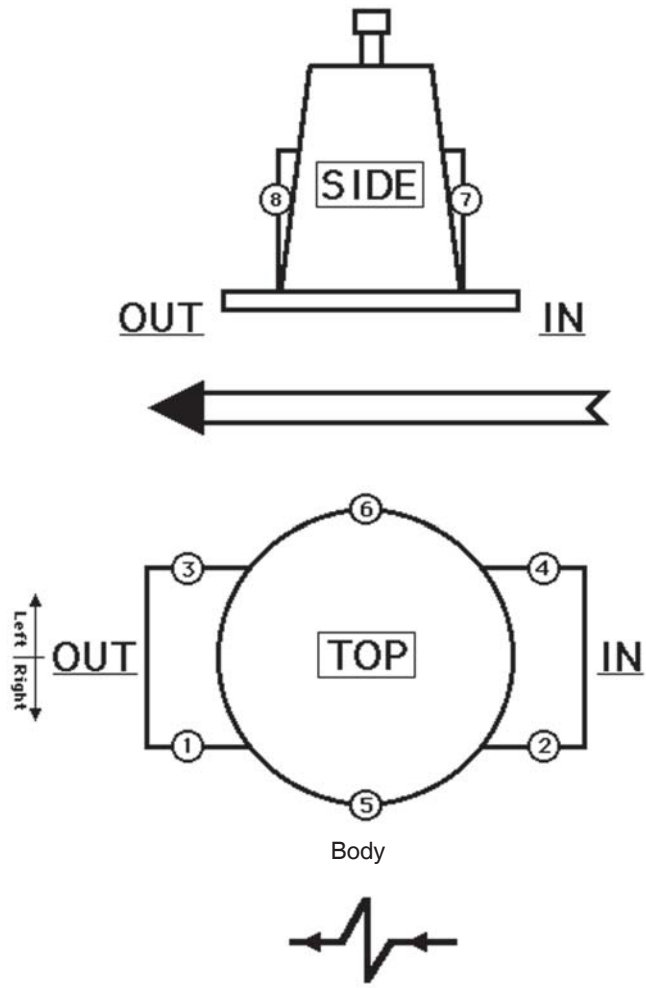

**Flow To Open Direction**

Location	Description	Opt. No.	NPT - Size	Body Mat'l.
1 & 2	Inlet & Outlet – Right	STD	1/4"	DI, CS & SST
1, 2 & 3	Inlet & Outlet – Right	STD	1/4"	BRZ
5	External Sensing – Right	STD	1/4"	ALL
1, 2, 3 & 4	Inlet & Outlet – Right Inlet & Outlet – Left	85	1/4"	ALL
5 & 6	Double External Sensing	85	1/4"	ALL

Location	Description	Opt. No.	NPT - Size	Sp. Ch. Mat'l.
7	Spring Ch. – Inlet Side	STD	1/4"	ALL
7 & 8	Double Spring Ch.	65A	1/4"	ALL
	Double Spring Ch.	65B	1/2"	CS ONLY
	Double Spring Ch.	65C	3/4"	
	Double Spring Ch.	65D	1"	

## DIMENSION and WEIGHTS

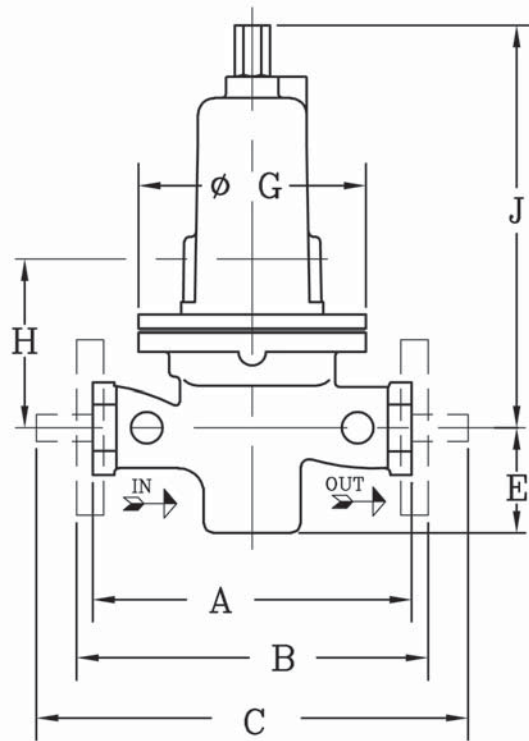

**ENGLISH UNITS (in) (lbs)**

DIMEN.	END CONN.	BODY MAT'L	BODY SIZE				
			1/2", 3/4 & 1"	1-1/4" & 1-1/2"	2"	3"	4"
A	NPT	DI, BRZ	6.00	9.88	9.88	-	-
		CS, SST	8.25	9.88	9.75	-	-
B	125# FF	DI	-	-	-	11.75	13.88
	250# RF	DI	-	-	-	12.50	14.50
	150# FF	BRZ **	9.63	11.50 ✓	11.50	11.75	13.88
	300# FF	BRZ **	9.63	11.50 ✓	11.50	12.15	14.50
	150# RF	CS, SST	10.75	12.38 ✓	10.00	11.75	13.88
	150# RF ‡	CS, SST	14.00	14.00 ✓	14.00	-	-
	300# RF	CS, SST	10.75	12.38 ✓	10.50	12.15	14.50
	300# RF ‡	CS, SST	14.00	14.00 ✓	14.00	-	-
	600# RF	CS, SST	10.75	12.38 ✓	11.25	13.25	15.50
	600# RF ‡	CS, SST	14.00	14.00 ✓	14.00	-	-
C	OPT-32 EXT NIPS	CS, SST	14.00	15.75	15.75	-	-
	OPT-41	SST	11.00	15.25	15.50	-	-
E	ALL	ALL	2.84	3.69	4.00	5.75	7.00
G	ALL	ALL	6.00	7.00	8.00	11.00	11.13
H	ALL	BRZ/DI †	5.00	5.44	5.80	8.50	8.50
	ALL	CS/SST †	6.10	6.36	6.91	10.50	10.50
J	ALL	ALL	10.13	12.63	13.00	23.00	23.50
WEIGHT	wo/ Flanges	ALL	23	33	39	-	-
	w/Flanges	ALL	28	43	52	175	190

**METRIC UNITS (mm) (kg)**

END CONN.	BODY MAT'L	BODY SIZE				
		DN15, DN20 & DN25	DN32 & DN40	DN50	DN80	DN100
NPT	DI, BRZ	152	251	251	-	-
	CS, SST	209	251	248	-	-
125# FF	DI	-	-	-	298	352
250# RF	DI	-	-	-	318	368
150# FF	BRZ **	246	292 ✓	292	298	352
300# FF	BRZ **	246	292 ✓	292	309	368
150# RF	CS, SST	273	314 ✓	254	298	352
150# RF ‡	CS, SST	356	356 ✓	356	-	-
300# RF	CS, SST	273	314 ✓	267	309	368
300# RF ‡	CS, SST	356	356 ✓	356	-	-
600# RF	CS, SST	273	314 ✓	286	336	394
600# RF ‡	CS, SST	356	356 ✓	356	-	-
OPT-32 EXT NIPS	CS, SST	356	400	400	-	-
OPT-41	SST	279	387	394	-	-
ALL	ALL	72	94	102	146	178
ALL	ALL	152	178	203	279	283
ALL	BRZ/DI †	127	138	147	216	216
ALL	CS/SST †	155	161	175	267	267
ALL	ALL	257	321	330	584	597
wo/ Flanges	ALL	11	16	18	-	-
w/Flanges	ALL	13	20	24	79	86

\*\* Flanged BRZ bodies available in sizes 1", 1-1/2", 2", 3", & 4" ONLY.

† Spring Chamber material.

✓ Flange Connections not available for 1-1/4" body size.

‡ Opt-34: Special 14" F to F Flange dimensions, CS and SST body material only.  
Consult Factory for dimensions of ISO DIN Flanged units. (PN16, PN25, PN40)

## NOTES

---

The contents of this publication are presented for informational purposes only, and while every effort has been made to ensure their accuracy, they are not to be construed as warranties or guarantees, express or implied, regarding the products or services described herein or their use or applicability. We reserve the right to modify or improve the designs or specifications of such product at any time without notice. Cashco, Inc. does not assume responsibility for the selection, use or maintenance of any product. Responsibility for proper selection, use and maintenance of any Cashco, Inc. product remains solely with the purchaser.

# MODEL DA8 PRODUCT CODER 03/14/16

An "X" in POS 12 followed by a 5-digit control number overrides remaining selections.

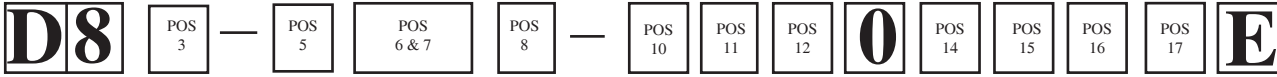

POSITION 3 SIZES & DIAPHRAGM CONSTRUCTION			
Body Size		Diaphragm Support	
in	(DN)	STD CODE	OPT-81 CODE
1/2"	(15)	4	J
3/4"	(20)	5	K
1"	(25)	6	L
1-1/4"	(32)	7	M
1-1/2"	(40)	8	N
2"	(50)	9	P
3" ^	(80)	B	NA
4" ^	(100)	C	NA

^ Not available with metal diaphragms.  
NA Not Available

POSITION 5 BODY & SPRING CHAMBER MATERIALS			
Materials	CODE	Materials	CODE
DI/DI	1	LCC/LCC * / **	6
BRZ/DI	2	LCC/SST *	8
BRZ/BRZ ††	B	SST/DI	7
CS/DI	4	SST/CS * √	9
CS/CS * √	5	SST/SST *	A

\* For Opt-81 Select CS, LCC or SST Spring Chamber Material except in Canada, use SST. See Table 1. NOTE: (CS Spg Chmb Mat'l in Sizes 3"-4" not registered for shipment into Canada.)  
\*\*LCC Mat'l not available in 3" - 4".  
†† Sizes 1/2" - 2"

POSITION 6 & 7 - DIAPHRAGM AND SEAT MATERIALS						
Trim Material	O-ring/Seal				CODE	
	Seat	Diaphragm	Static	Dynamic		
17-4PH SST "P"	PA	BC	NBR	SST/TFE u-cup	P2	
	CTFE	BC	NBR	SST/TFE u-cup	P3	
	PA	NBR	NBR	SST/TFE u-cup	P6	
	PA	FK	FK	SST/TFE u-cup	P7 ‡	
	GF-TFE	FK	FK	SST/TFE u-cup	P8 ‡	
	V-TFE	FK	FK	SST/TFE u-cup	P9 ‡	
	PA	FKM	FKM	SST/TFE u-cup	PB	
	GF-TFE	FKM	FKM	SST/TFE u-cup	PD	
	V-TFE	FKM + TFE	SST/TFE u-cup	SST/TFE u-cup √	PE	
	GF-TFE	3-ply	RTFE	SST/TFE u-cup \$	PF	
	GF-TFE	3-ply	RTFE	PRA \$	PG	
	PA	NBR	NBR	TFE+NBR CP	PH	
	PA	EPR	EPR	TFE+EPR CP	PJ	
	PA	FK	FK	TFE+FK CP	PK	
	GF-TFE	FKM	FKM	TFE+FKM CP	PL	
	Monel "M"	FKM	FKM	FKM	SST/TFE u-cup	PZ
PA		FK	FK	SST/TFE u-cup ††	M7 ‡	
V-TFE		FK	FK	SST/TFE u-cup	M9 ‡	
V-TFE		FKM-TFE	SST/TFE u-cup	SST/TFE u-cup √	ME	
PA		NBR	NBR	TFE+NBR CP	MH	
PA		EPR	EPR	TFE+EPR CP	MJ	
PA		FK	FK	TFE+FK CP	MK	
GF-TFE		FKM	FKM	TFE+FKM CP	ML	
FKM		FKM	FKM	SST/TFE u-cup	MZ	
316L SST "S"		PA	FK	FK	SST/TFE u-cup	S7 ‡
		V-TFE	FK	FK	SST/TFE u-cup	S9 ‡
		PA	BE-CU *	SST/TFE u-cup	SST/TFE u-cup	SM
		V-TFE	BE-CU *	SST/TFE u-cup	SST/TFE u-cup	SN
		PA	NBR	NBR	TFE+NBR CP	SH
		PA	EPR	EPR	TFE+EPR CP	SJ
		PA	FK	FK	TFE+FK CP	SK
	GF-TFE	FKM	FKM	TFE+FKM CP	SL	
17-4PH/Monel/17-4PH "T"	PA	FK	FK	SST/TFE u-cup ††	T7 ‡	
	V-TFE	FK	FK	SST/TFE u-cup	T9 ‡	
	PA	BE-CU *	SST/TFE u-cup	SST/TFE u-cup	TM	
	V-TFE	BE-CU *	SST/TFE u-cup	SST/TFE u-cup	TN	
	PA	NBR	NBR	TFE+NBR CP	TH	
	PA	EPR	EPR	TFE+EPR CP	TJ	
	PA	FK	FK	TFE+FK CP	TK	
	GF-TFE	FKM	FKM	TFE+FKM CP	TL	

\* 3" - 4" sizes are not available with metal diaphragm.  
‡ For Low Ambient Temperatures (See DAG for Min. Temperatures)  
†† For GOX service, PA seats allowed in BRZ Bodies only.  
√ Sizes 3"-4" use V-TFE static seal.  
\$ For Steam applications Max Press < 125 psig. Abbreviations defined on page 2

POSITION 8 - Product Classification Under European "Pressure Equipment Directive"		
PRODUCT DESTINATION	HAZARD CATEGORY	CODE
Anywhere except Europe	N/A	7
European Countries * (CE Mark does not apply to DN25 and below)	Sound Engineering Practice (SEP)	S
	CE Marked Hazard Cat I or II	E

\* For products to be placed in service in Europe - Ref to Directive 97/23/EC. Forward Completed "EU" Application Recorder prior to quotation. (Without Recorder-Processing of Purchase Order will be delayed). Contact Cashco for Assistance.

POSITION 10 - END CONNECTIONS / ASME								
Size	Material	Method	End Conn	CODE	End Conn	CODE	End Conn	CODE
1/2" - 2"	ALL	-	NPT	1	-	-	-	-
2-1/2" - 4"	DI	Integral	125#FF	2	250#RF	3	-	-
1", 1-1/2" - 4"	BRZ	Integral	150#FF	6	300#FF	7	-	-
1/2" - 3/4"	CS,SST	Opt-30	150#RF	4	300#RF	5	600# RF	8
1" - 4"	CS,SST	Integral *	150#RF	4	300#RF	5	600# RF	8
1/2" - 2"	ALL	Opt-31	BSP	P	-	-	-	-
1/2" - 2"	CS, SST	Opt-32	Extended Nipples		E	-	-	-
1/2" - 2" (F to F)	CS, SST	Opt-34 *	150#RF	V	300#RF	W	600#RF	Y
1/2" - 1", 1-1/2" - 2	SST	Opt-41	Non-High Purity Tube Ends		T	-	-	-

END CONNECTIONS FOR ISO DIN FLANGES								
DN15-25, 40, 50	BRZ	Integral	PN40 FF - will mate with PN16, 25 and 40			J		
DN65-100			PN16 FF	K	PN25 FF	L	PN40 FF	M
DN15-25, 40, 50	CS, SST	Opt-30	PN40 RF - will mate with PN16, 25 and 40			D		
DN80-100	CS, SST	Integral	PN16 RF	A	PN25 RF	C	PN40 RF	G

\* Flanges Not Available for 1-1/4" (DN32) size.  
\*\* 1" size w/ 600# RF CS,or SST has weld-on flanges Opt-30.

POSITION 11 - RANGE SPRINGS							
Body Size	Pressure Range		CODE	Body Size	Pressure Range		CODE
	psid	bard			psid	bard	
1/2" 3/4" 1" (DN15, 20 & 25)	1-5 ^	.07-.34	1	2" (DN50)	1-5 ^	.07-.34	1
	1-10 *	.07-.68	S		1-10 *	.07-.68	S
	5-20	.34-1.3	A		5-15	.34-1.0	M
	10-35	.68-2.4	B		10-30	.68-2.0	N
	20-80	1.3-5.5	C		15-50	1.0-3.4	P
1-1/4" 1-1/2" (DN3 & 40)	30-150	2.0-10.3	D	30-90	2.0-6.2	Q	
	70-200	4.8-13.7	E	1-10	.07-.68	S	
	1-5 ^	.07-.34	1	3" & 4" (DN80 & 100)	5-20	.34-1.3	A
					10-40	.68-2.7	T
					10-70	.68-4.8	J
40-125					2.7-8.6	K	
1-10 *	.07-.68	S	^ Composition diaphragm construction ONLY				
5-20	.34-1.3	A	* Metal Diaphragm for P <sub>sp</sub> ≥ 5 psid. (.34Bard)				
15-45	1.0-3.1	H					
10-70	.68-4.8	J					
40-175	2.7-12.0	2					

POSITION 12 - SENSING FLOW DIRECTION	
Option	Flow To Open CODE
Internal	1
External	2
Large Internal	4
For Special Construction Contact Cashco for Special Code	X

POSITION 14 - SPRING CHAMBER OPTIONS		
Description	Option	CODE
Std Flow-thru connections 1/4"	-64A	F
Flow-thru Spring Chamber, 1/2" NPT CS Material ONLY.	-65B	G
Flow-thru Spring Chamber, 3/4" NPT CS Material ONLY.	-65C	H
Flow-thru Spring Chamber, 1" NPT CS Material ONLY.	-65D	K

POSITION 15 - BODY OPTIONS		
Description	Option	CODE
No Option	-	0
Second "SET" of 1/4" (DN8) FNPT Pressure Taps & Plugs.	-85	T

POSITION 16 - CERTIFICATE OPTIONS		
Description	Option	CODE
No Option	-	0
SPECIAL CLEANING: Per Cashco Spec #S-1134. W/ properly selected mat'l's. Suitable for Oxygen Service. BRZ or SST body material.	-55	M
SPECIAL CLEANING: Per Cashco Spec #S-1542.	-56	N
SPECIAL CLEANING: Per Cashco Spec #S-1589 Cl <sub>2</sub> Service.	-57	P

POSITION 17 - PAINT OPTIONS		
Description	Option	CODE
No Option	-	0
Epoxy Painted Per Cashco Spec #S-1547.	-95	W
Epoxy Painted Per Cashco Spec #S-1687 OFFSHORE Applic.	-95OS	Y



Cashco, Inc.  
P.O. Box 6  
Ellsworth, KS 67439-0006  
PH (785) 472-4461  
Fax. # (785) 472-3539  
www.cashco.com  
email: sales@cashco.com  
Printed in U.S.A. DA8-TB

Cashco GmbH  
Handwerkerstrasse 15  
15366 Hoppegarten, Germany  
PH +49 3342 30968 0  
Fax. No. +49 3342 30968 29  
www.cashco.com  
email: germany@cashco.com

Cashco do Brasil, Ltda.  
Al.Venus, 340  
Indaiatuba - Sao Paulo, Brazil  
PH +55 11 99677 7177  
Fax. No.  
www.cashco.com  
email: brazil@cashco.com