



Alfa Laval DuroCore

Plate-and-shell heat exchanger for high pressure duties

Designed for demanding gas compression duties in the harshest of offshore environments, Alfa Laval DuroCore is a compact welded heat exchanger solution with exceptional capabilities.

At heart the Alfa Laval DuroCore is a plate-and-shell heat exchanger but each unit is engineered uniquely to meet the specific customer's needs. Innovative plate design and state-of-the-art welding technology allows for design pressures of up to 250 barG in 316L SST and 200 barG in titanium.

Applications

Alfa Laval DuroCore is designed specifically to tackle high-pressure duties in the challenging offshore gas industry with design pressures ranging from vacuum to 250 barG (3,626 psiG).

Benefits

- Large fluid channels and the patented roller coaster pattern of the plates ensure high reliability in operation and maximum uptime
- Substantial savings in footprint and weight compared to traditional shell and tube exchangers. Up to 50% lighter than a corresponding shell-and-tube heat exchanger.
- Available in titanium, which enables direct cooling with seawater
- The removable core makes it easy to reach internal parts and allows for maintenance

Working principles

The heat exchanger operates with the cooling media on the plate side and the high-pressure gas on the shell side. The patented roller coaster pattern gives a long thermal length ensuring high thermal efficiency and the mechanical strength needed for the high design pressures.

The plate pattern varies over the surface of the plate, ensuring even pressure drop and flow distribution across the plate and eliminating localized dead spots, where hydrate formation could occur.



The central distribution tube ensures that the cooling media enters down the middle of the plate, flows around the plate and then exits the other side. Since the nozzles on the shell side are completely independent to those on the plate side the heat exchanger is perfect for asymmetric flow duties.

Design

Alfa Laval DuroCore is based on 3 different plate configurations, which allow a high degree of customization to best fit the individual process requirements. Heat transfer surface area ranges from 93–800 m² (1,001–8,611 ft²). Heat exchange plates are made of 316L SST, or titanium (depending on the cooling media used), and the pressure vessel shell is in carbon steel.

Design data

| | |
|---------------------------|-----------------------|
| Min. temperature, °C (°F) | -45 °C (-49 °F) |
| Max. temperature, °C (°F) | 200 °C (392 °F) |
| Min. pressure | vacuum |
| Max. pressure | 250 barG (3,626 psiG) |
| Min. number of plates | 80 |
| Max. number of plates | 700 |

Weight

| | Min. | Max. |
|------------------|-----------------|-----------------|
| Dry kg (lbs) | 11,170 (24,625) | 31,100 (68,564) |
| Flooded kg (lbs) | 11,400 (25,132) | 33,500 (73,855) |

Technical data

| | |
|-------------------------------|---|
| Materials (plates) | 316L SST or Titanium |
| Material (shell) | Carbon steel grade SA516 gr. 70 |
| Maximum heat transfer surface | 800 m ² (8,611 ft ²) |

Connection sizes and ratings are tailored to the specific design requirements.

| Dimension | Min. | Max. |
|------------|-------------|--------------|
| H1 mm (in) | 100 (4") | 1,535 (60") |
| H2 mm (in) | 200 (8") | 3,070 (120") |
| H3 mm (in) | 1,000 (40") | 3,870 (152") |
| D1 mm (in) | 1,440 (56") | 1,570 (62") |
| D2 mm (in) | 1,740 (68") | 1,800 (70") |
| D3 mm (in) | 1,330 (52") | 1,330 (52") |
| D4 mm (in) | 540 (21") | 540 (21") |
| W1 mm (in) | 2,300 (90") | 2,550 (100") |
| W2 mm (in) | 1,210 (48") | 1,210 (48") |

Dimensional drawing

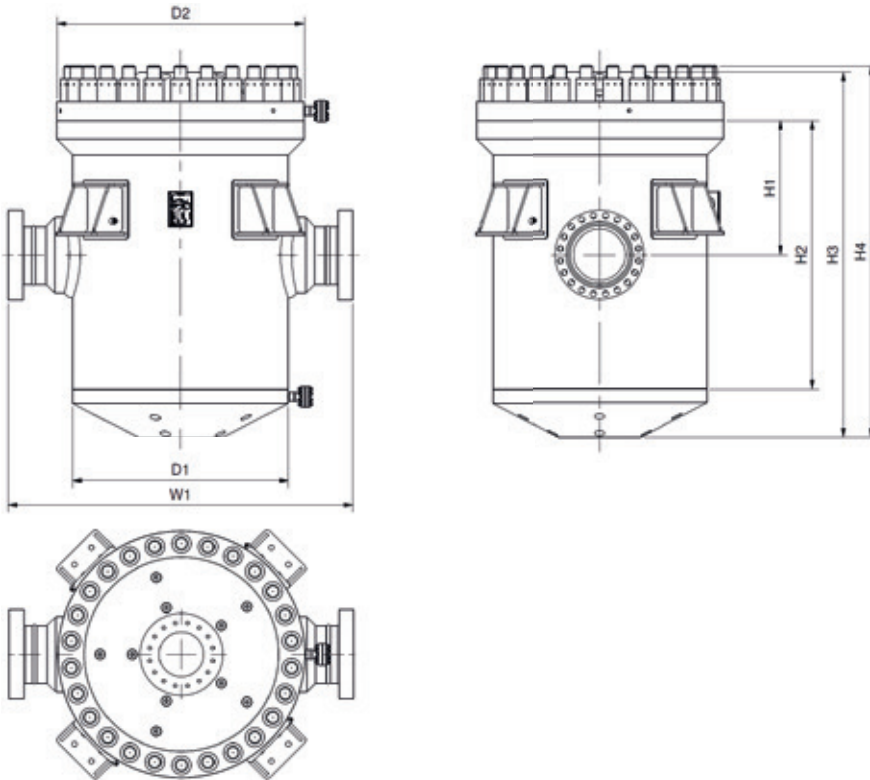

Alfa Laval reserves the right to change specifications without prior notification.

How to contact Alfa Laval

Up-to-date Alfa Laval contact details for all countries are always available on our website at www.alfalaval.com