

RM 6006

Interroll Lift



Product Description

The lifting station consists of a column construction and a carriage upon which a roller conveyor is mounted. A worm gear motor with brake is used as a drive unit to raise and lower the carriage via a belt.

Technical data

General technical data	Max. load capacity*	150 kg
	Stroke velocity	0.1 to 0.6 m/s
	Ambient temperature	-5 to +40 °C
	Max. stroke height	6000 mm
	Startup position	2
	Lifting column	200 x 80 mm (aluminum profile)
Drive	Motor type	Worm gear motor with brake, frequency regulation on site
	Rated voltage	400 V/50 Hz/3 phase
	Max. electrical power	2.2 kW
	Drive medium	Belt

* The combination of maximum values is not always possible.

Dimensions

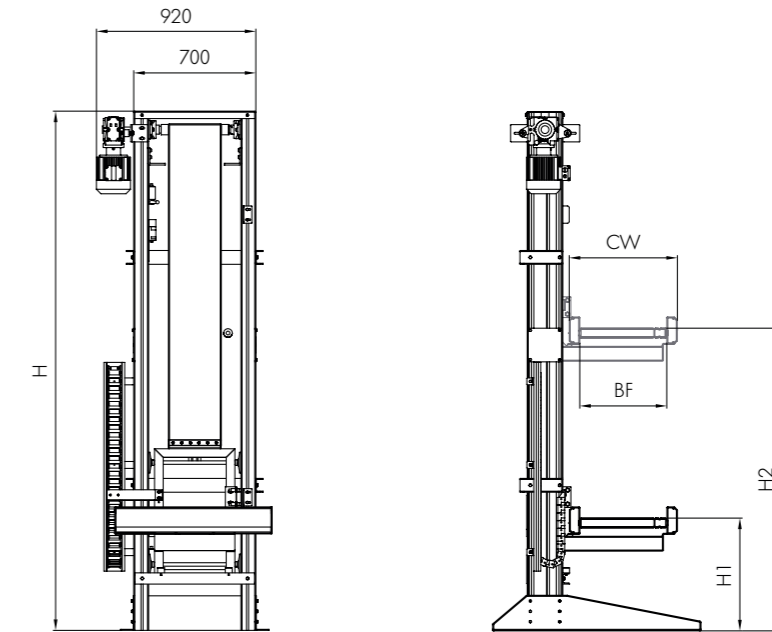

BF	Between frames	420, 620, 840 mm (when using Interroll modules)
H1	Lower level dimension	Min. 300 mm
H2	Upper level dimension	H1 + stroke height
H	Overall height	H2 + 600 (max. 8000 mm)
CW	Width of mounted conveyors	Max. 1300 mm

Note: The upper part of the lifting station must be supported on site above an overall height of 4000 mm.

Scope of supply

- The module is fully assembled, including sensor system, but is not electrically cabled.
- Energy chain is pre-installed
- Please request protective grid and safety elements separately
- Without conveyor module