

Operating Instructions for Float Flow Meter / Monitor

Model: SWK



1. Contents

1. Contents.....	2
2. Note	3
3. Instrument Inspection.....	3
4. Regulation Use.....	4
5. Operating Principle.....	4
6. Use in Hazardous Areas	5
6.1 General	5
6.2 Electrical Contact.....	5
6.3 Equipotential Bonding.....	5
7. Mechanical Connection.....	6
8. Electrical Connection	6
9. Operation / Configuration / Adjustments	7
9.1 Adjustment of Limit-Value (SWK-1...)	7
9.2 Adjustment of Limit-Value (SWK-2...)	7
10. Maintenance	8
11. Technical Information.....	8
12. Order Codes	9
13. Dimensions	10
14. Declaration of Conformance	11

Manufactured and sold by:

Kobold Messring GmbH
Nordring 22-24
D-65719 Hofheim
Tel.: +49(0)6192-2990
Fax: +49(0)6192-23398
E-Mail: info.de@kobold.com
Internet: www.kobold.com

2. Note

Please read these operating instructions before unpacking and putting the unit into operation. Follow the instructions precisely as described herein.

The devices are only to be used, maintained and serviced by persons familiar with these operating instructions and in accordance with local regulations applying to Health & Safety and prevention of accidents.

When used in machines, the measuring unit should be used only when the machines fulfil the EWG-machine guidelines.

as per PED 97/23/EG

In acc. with Article 3 Paragraph (3), "Sound Engineering Practice", of the PED 97/23/EC no CE mark.

Diagram 8, Pipe, Group 1 dangerous fluids

3. Instrument Inspection

Instruments are inspected before shipping and sent out in perfect condition.

Should damage to a device be visible, we recommend a thorough inspection of the delivery packaging. In case of damage, please inform your parcel service / forwarding agent immediately, since they are responsible for damages during transit.

Scope of delivery:

The standard delivery includes:

- Float Flow Meter / Monitor Model: SWK
- Operating Instructions

4. Regulation Use

These units, type SWK, are used for the purpose of measuring and monitoring liquid flow. Only clean, low-viscous and homogeneous liquids may be measured which do not chemically attack the materials used in the construction of these units. An attempt to measure high-viscous liquids may lead to considerable measurement errors.

Large dirt-particles can cause the blockage of float and subsequently turn on error indications. Also, ferrite particles, which deposit on float (with embedded magnets), can generate the same effect (we recommend a magnet-filter).

These units are configured in the following manner:

- Housing made of Brass, St. Steel or PVC
- Attached reed contact N/O with 1m PVC cable (Brass version)
- Attached reed contact N/O with 2m PVC cable (PVC/VA version)
- Attached and aligned pointer display (option)

5. Operating Principle

KOBOLD Flow Meter/Monitor of type SWK operates according to the well known float principle, however without making use of the generally employed extended measuring tube. Inside a cylindrical flow-tube a float with aperture moves in the direction of the flow against the recoiling force of a spring. Within the float, a pair of magnets is located which trigger a potential-free protective-gas reed contact and drives a pointer display. The reed contact is mounted on the exterior of the flow-housing. The springs arrangement allows the unit to be operated without consideration to mounting position and keeps the installation dimensions to a minimum. Flow monitors of type SWK generally find application where small volume flow needs to be measured in a fail-safe manner.

6. Use in Hazardous Areas

6.1 General

The Flow Meter/ Monitor does not have a potential igniting source of its own as a mechanical operating resource; it does not get any identification according to the guideline 94/9/EC ("ATEX 100a").

The mounted contact can be used in intrinsically safe circuits as a "simple apparatus" according to EN 60079-14. The following limit values for the switching contact should not be exceeded: $U = 30 \text{ VDC}$, $I = 100 \text{ mA}$, $P = 1,2 \text{ W}$.

The measurement units can be used as follows:

- a) In the Zone 2 (Gas-Ex, Cat. 3G) into explosion group of IIA, IIB and IIC
- b) In the Zone 22 (Dust-Ex, Category 3D) at non-conductive dusts with a minimum igniting energy of $> 3 \text{ mJ}$
- c) In the Zone 1 (Gas-Ex, Cat. 2G) into explosion group of IIA, IIB and IIC
- d) In the Zone 21 (Dust-Ex, Category 2D) at non-conductive dusts with a minimum igniting energy of $> 3 \text{ mJ}$

6.2 Electrical Contact

In the Ex-area, the Flow Meter/ Monitor can be used according to Category 2G and 2D for group II; in Zone 1 and 21 in connection with a switching amplifier for protection type Ex II (2)GD [EEx ia] IIC (intrinsically safe).

The electrical connection is explained in section 8 Electrical Connection.

6.3 Equipotential Bonding

The Flow Meter/ Monitor will allow equipotential bonding of the equipment. This will occur only when the connection pipes are made of metal.

7. Mechanical Connection

Before installation:

- Make sure that the permitted maximum operating pressure and the operating temperature of the device are not exceeded.
- Make sure that the electrical supply for the devices corresponds with the operational data of the device.
- Make sure that no remains of packing material exist within the device.
- The devices should not be installed within an inductive field.
- If possible, it should be checked, after the mechanical installation whether the connection joints/ piping is properly sealed.



Attention! A displacement of switching range occurs if the flow takes place from top to bottom.

8. Electrical Connection



Attention! Make sure that the voltage values of your system correspond with the voltage values of the measuring unit, mentioned on type-label.

- Make sure that the supply wires are de-energized.
- The connection of the bistable reed contact succeeds is accomplished through the cable on the contact housing. The potential-free contact closes on rising level above the adjusted flow value.

9. Operation / Configuration / Adjustments

The commissioning of these units is prohibited in machines (as long as the guidelines 89/392/EWG remain enforced), which do not comply with these guidelines.

The unit is supplied in 'ready for operation' condition. The switching point is adjusted on the lowest scale value.

9.1 Adjustment of Limit-Value (SWK-1...)

- Loosen the knurled nut on the reed contact.
- Adjust the marking on the contact for the desired value on the scale. In once positioned the knurled nut should be tightly screwed.

9.2 Adjustment of Limit-Value (SWK-2...)

- Loosen the knurled nut on the reed contact.
- Connect a suitable continuity-tester on cable ends.
- **Case 1: On an installed unit**
- Open the supply line, and let the flow-medium enter slowly, till the pointer display shows the desired flow value- at which the rising flow should operate the switch (the value for the decreasing flow lies below due to the hysteresis).
- **Case 2: On an uninstalled unit** the adjustment may be performed by lifting the float with a suitable tool.
- Switch-housing is repositioned from top to bottom, till the reed contact just closes (electrical continuity). In this position, secure the contact by tightening the knurled nut.

The unit is now adjusted and ready for operation.

On correct adjustment, the limit-value contact performs bistable action. That means, even after on crossing above the adjusted limit-values, the contact remains closed.

Hysteresis

Hysteresis is an indication of difference between switch-on (rising float) and switch-off (falling float) points of a contact. The average hysteresis corresponds to a float-centre movement of about 3 mm.

10. Maintenance

As long as the medium to be measured is not contaminated, the device SWK is almost maintenance-free. With lime or such depositions within inner sections the device should be cleaned regularly.



Attention! Before the commencement of maintenance work, make sure that the supply wires are de-energized.

11. Technical Information

Housing/Float:	SWK-x1...: brass nickel plated, Ms 58 SWK-x2...: stainless steel, 1.4301 SWK-13...: PVC
Connections:	G 1/2 female
Float:	SWK-x1...: brass, Ms 58 SWK-x2...: stainless steel, 1.4301 SWK-13...: PVC
Magnets:	ceramic
Compression spring:	stainless steel 1.4310
Gaskets:	none
Butt rings:	SWK-x1...: brass, Ms 58 SWK-x2...: stainless steel, 1.4301 SWK-x13...: PVC
Max. temperature:	SWK-x1..., SWK-x2: 100 °C SWK-13...: 60 °C
Max. pressure:	SWK-x1..., SWK-x2: 250 bar SWK-13...: 6 bar
Loss of pressure:	200 mbar at ME
Installation position:	any position
Switch contact:	bistable reed contact N/O contact or changeover contact with increasing flow rate
Breaking capacity N/O contact:	max. 230 V _{AC/DC} , max. 3 A max. 60 W/VA
Changeover contact:	(SWK-xxxxU) max. 100 V _{AC/DC} , max. 0.5 A, max. 5W/VA
Electr. connection:	1 m PVC cable
Switching hysteresis:	3 mm on scale (mean value)
Repeatability:	≤ 2.5 % (contact) ± 4 % f. s. (indicator)
Protection:	IP 68 contact; IP 54 indicator
Ex range:	ATEX Zone 1 as "simple apparatus"

Average electrical switch contact life (MTTF):

at max. electrical load: 10^5 switching operations
 at half load (<10%max. load): $5 \cdot 10^7$ switching operations
 at low load (<10V/<1mA): 10^8 switching operations

12. Order Codes

Example: **SWK-1101**

Switching range L/min. water	Connection female	Flow monitors			Flow meters and monitors		Switch contact
		Material brass	Material stainless steel	Material PVC	Material brass	Material stainless steel	
0.05 - 0.1	G 1/2	SWK 1101	SWK 1201	-	SWK 2101	SWK 2201	without = N/O contact u = changeover contact
0.1 - 0.2	G 1/2	SWK 1102	SWK 1202	-	SWK 2102	SWK 2202	
0.2 - 0.8	G 1/2	SWK 1108	SWK 1208	SWK 1308	SWK 2108	SWK 2208	
0.5 - 1.8	G 1/2	SWK 1118	SWK 1218	SWK 1318	SWK 2118	SWK 2218	
1.7 - 4.0	G 1/2	SWK 1140	SWK 1240	SWK 1340	SWK 2140	SWK 2240	
4.0 - 9.0	G 1/2	SWK 1190	SWK 1290	SWK 1390	SWK 2190	SWK 2290	
8 - 16	G 1/2	SWK 1116	SWK 1216	SWK 1316	SWK 2116	SWK 2216	
13 - 24	G 1/2	SWK 1124	SWK 1224	SWK 1324	SWK 2124	SWK 2224	

13. Dimensions

SWK-1...

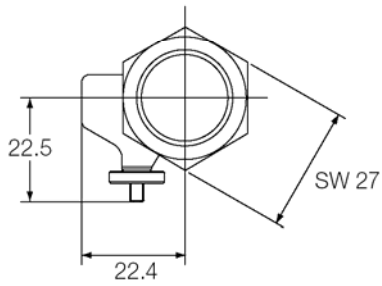
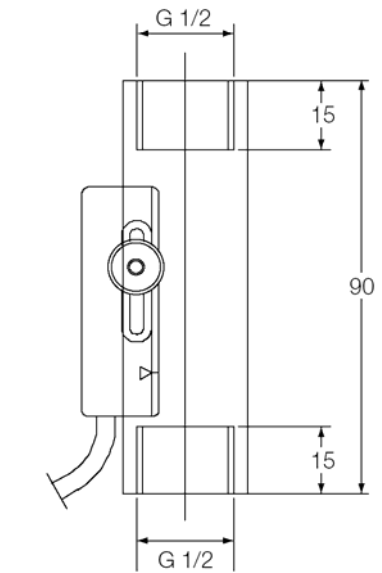

SWK-2...

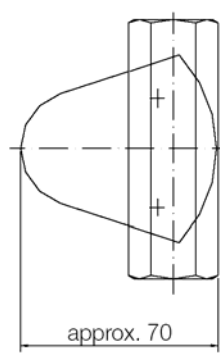
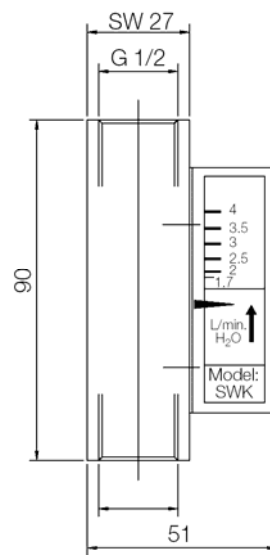

14. Declaration of Conformance

We, KOBOLD Messring GmbH, Hofheim-Ts, Germany, declare under our sole responsibility that the product:

Float Flow Meter / Monitor Model: SWK...

to which this declaration relates is in conformity with the standards noted below:

DIN EN 61010-1 1994-03
Safety requirements for electrical equipment for measurement, control and laboratory use

IEC529, DIN VDE 0470-1 1992-11
Protection through housing (IP-Code)

Also, the following EWG guidelines are satisfied:

2006/95/EC Low Voltage Directive

Hofheim, 16. Jan. 2007



H. Peters
General Manager



M. Wenzel
Proxy Holder