

KOBOLD DSF26 Digital Pressure Gauge

User Instructions



KOBOLD Instruments Inc. 1801 Parkway View Drive Pittsburgh PA 15205

Phone (412) 788-2830 • Fax (412)-788-4890 • www.koboldusa.com

Table Of Contents

KOBOLD DSF26 DIGITAL PRESSURE GAUGE

1.0	General	1
2.0	Specifications	2
3.0	Installation Instructions	5
4.0	Operation	6
4.1	Turning the Unit On	6
4.2	Flow Measurement	6
5.0	Arrival of Damaged Equipment	6
6.0	Maintenance	6
7.0	Need Help With Your DSF26?	6

List of Diagrams

Diagram 2.4:	Sensor Dimensions	4
Diagram 3.1:	Wiring	5

List of Tables

Table 2.1:	Material Combinations and Maximum Limits	2
Table 2.2:	Electrical Data	3
Table 2.3:	Flow Ranges and Fitting Sizes	3

KOBOLD DSF26 DIGITAL PRESSURE GAUGE User Instructions

CAUTION: For safety reasons, please read the cautionary information located at the end of the manual, before attempting installation.

1.0 General

The DSF26 employs a piezo-resistive strain gauge element whose resistance varies in proportion to an applied force (pressure). This variable resistance signal is conditioned to provide an LED display and analog output. Optionally this meter can be provided with up to 4 switches whose switch points and hysteresis are programmable.

2.0 Specifications

Table 2.1: General Specifications

Ranges:	-14.7 to 5800 PSIG (see table 2.1 for model numbers)
Over Pressure Protection:	
To 3000 PSIG:	2X range Max.
Above 3000 PSIG:	1.5X range Max.
Sensor Type:	Piezoresistive
Accuracy:	±0.5% of full scale ± 1 digit
Linearity:	±0.2% of full scale
Repeatability:	±0.1% of full scale
Operating Temperature:	
Medium:	-5°F to 220°F
Ambient:	-5°F to 140°F
Storage:	-40°F to 160°F
Temperature Drift Coefficients	
Zero:	< 0.05% of full scale/°F
Span:	< 0,05% of full scale/°F
Sensing Membrane Location:	Internal
Optional:	Flush
Materials of Construction:	
Wetted Parts:	316 Ti-Stainless Steel, Sapphire
Housing:	304 Stainless Steel, Polyamide

Table 2.2: Electrical Data

Power Supply:	15-30 VDC, 300 mA Max. steady state, 1 Amp inrush
Analog Output:	
Current:	0-20 mA or 4-20mA into 500 ohms Max.
Voltage:	0-10 VDC into 500 Ohms Min.
Zero Adjust:	±25% of full scale
Relays (Optional):	
Type:	SPDT
Setpoints:	Field Adjustable
Hysteresis:	Field Adjustable
Max. Voltage:	250 VAC, 220 VDC
Max. Current:	3 Amps
Max. Power:	50 VA, 60 Watts
Displays:	
Pressure:	4 digit, 0.5", Green LED
Switch Setpoints:	4 Digit Backlit LCD
Electrical Connections:	Via Terminal Strip
Operating Temperatures:	
Medium:	-5° to 220°F
Ambient:	-5° to 140°F
Storage:	-40° to 160°F
Environmental Protection:	IP65 (equivalent to NEMA 4)

Table 2.3: Part Number Decoding

DSF26 Digital Pressure Gauge with Analog Output

Range	= Pressure Range Abbreviation	<u>Available Measuring Ranges</u>					
V15	= -14.7 to 0 PSIG	210	= 100 PSIG	270	= 700 PSIG	350	= 50
050	= 5 PSIG	215	= 150 PSIG	275	= 750 PSIG	358	= 58
110	= 10 PSIG	220	= 200 PSIG	310	= 1000 PSIG		
115	= 15 PSIG	230	= 300 PSIG	315	= 1500 PSIG		
130	= 30 PSIG	250	= 500 PSIG	320	= 2000 PSIG		
160	= 60 PSIG	260	= 600 PSIG	330	= 3000 PSIG		

1 = Internal Membrane

Sensing Membrane Location

- 1** = 1/4" NPT
- 2** = 1/2" NPT
- 3** = 3/4" NPT

Fittings

- 4** = 4-20 mA Output
- 0** = 0-20 mA Output
- 1** = 0-10 VDC Output

Analog Output

- G** = 2 SPDT Limit Switches
- H** = 4 SPDT Limit Switches

Switches

-115

1

2

4

G

Sample DSF26 Specification

Diagram 2.4: Dimensions

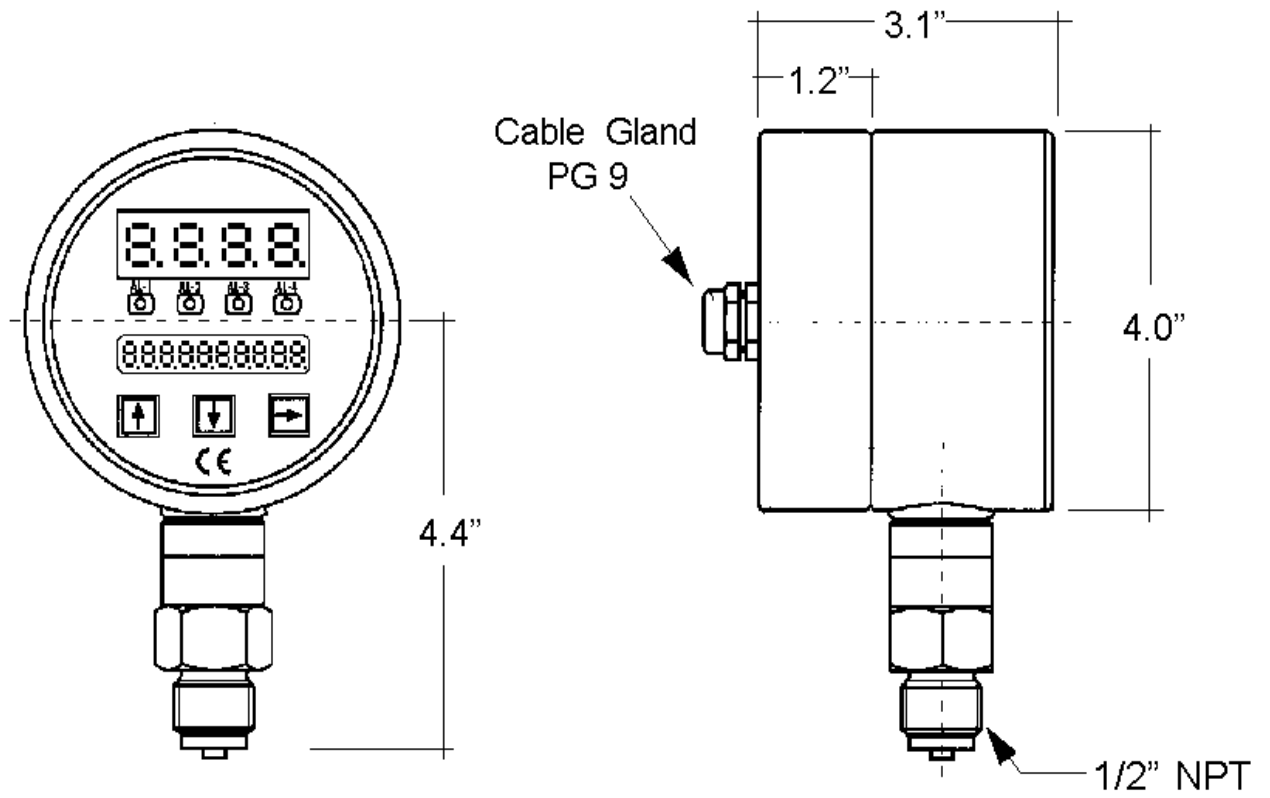

All dimensions in inches

3.0 Installation Instructions

CAUTION: For safety reasons, please read the cautionary information located at the end of the manual, before attempting installation.

The following instructions and recommendations must be adhered to in order to ensure proper pressure gauge installation:

1. When installed in horizontal piping runs, the gauge should be installed in the upper hemisphere of the pipe, at the 12 O'clock position or within $\pm 45^\circ$ of the 12 O'clock position. This will ensure that sediments which may build up at the bottom of the pipe will not clog the pressure sensing port (see Diagram 3.1).

Diagram 3.1: Pressure Gauge Installation

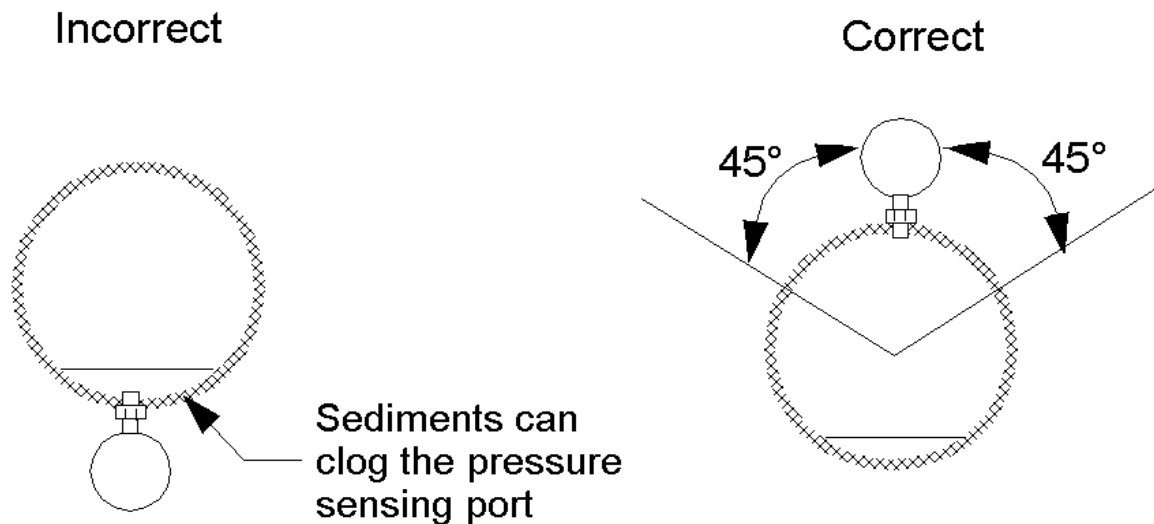

2. Install the gauge into a properly sized female port. Use of a thread sealant such as PTFE tape is recommended to ensure a leak-tight seal.
3. When tightening the gauge into the piping system use a properly sized wrench on the hex just above the threaded portion of the fitting. **Do not use the case of the gauge to apply torque or make or break the pressure connection.**

4.0 Electrical Connections

1. The DSF26 requires a 15-30 VDC power supply with at least 300 mA steady state current capability. The unit has an inrush current of up to 1 Amp during the initial startup transient. It is therefore necessary to ensure that the power supply used with the DSF26 has a transient short-time current capability of at least 1 Amp.
2. The analog output signal wiring (if used) is made using either a **3-wire or 4-wire** connection as specified by the following wiring diagram:

CAUTION: THE DSF26 IS NOT A LOOP POWERED (2-WIRE) DEVICE.
DO NOT ATTEMPT TO USE A 2-WIRE CONNECTION AS THE
INTERNAL ELECTRONICS WILL BE DAMAGED IMMEDIATELY!!!

Diagram 4.1: Wiring

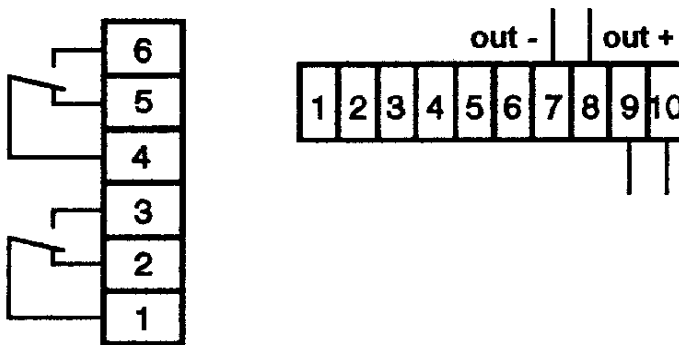

Note 1: Relays shown are optional

Note 2: Terminal blocks may be unplugged for wiring ease

Diagram 4.2: Power and Analog Output Connections

Terminal 10: DC Power (+)

Terminal 9: DC Power (-)

Terminal 8: Analog Output (+)

Terminal 7: Analog Output (-)

Terminals 1-6: Factory programming use only

5.0 Operation

Diagram 5.1 DSF26 Displays and Controls

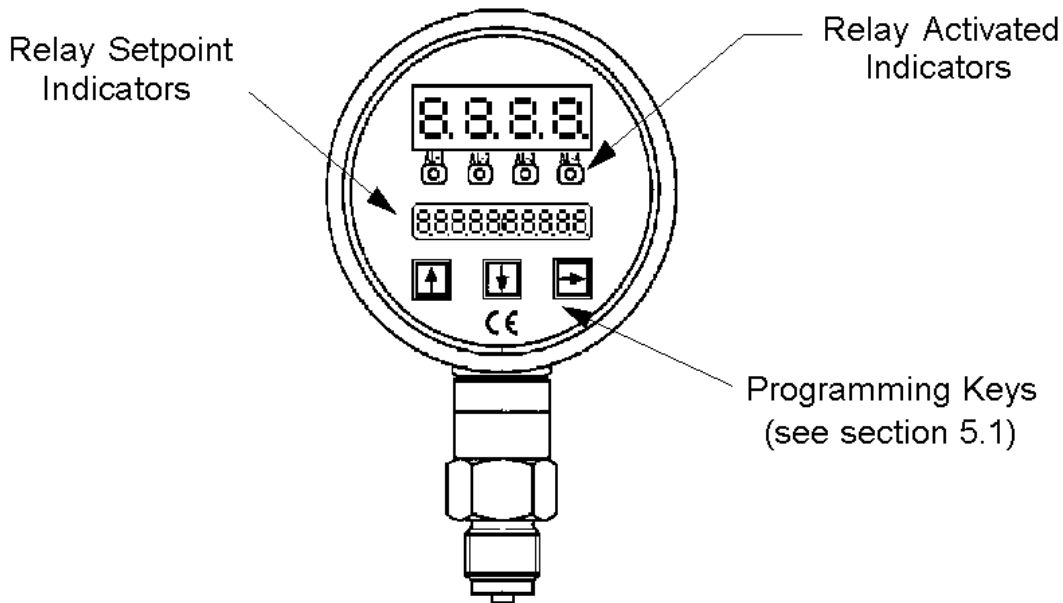

5.1 Programming, General

Programming is required in order to set the relay parameters and auto-zero the display if needed. The programming menu items are displayed on the LCD display below the main pressure display. The arrow keys on the front of the DSF26 are used to perform the programming as follows:

Depressing the  will place the DSF26 in the programming mode. **EO - EbEnE** will be displayed on the LCD display. There are 4 branches in the programming mode (see Diagram 5.2). Branch 1 sets Relay 1 parameters (setpoint, hysteresis etc.); Branch 2 sets the Relay 2 parameters; Branch three is used for auto-zeroing the display and branch four is used only by the factory for initial setup. Menu items in branch 4 are locked and cannot be altered by the user.

Programming key functions when in the programming mode (refer to Diagram 5.2)



Move to the next menu item



Move to the previous menu item



Move to the next branch. (only when at the first menu item in a branch)



Go back to the operating mode

5.1 Programming, General (cont.)

When the numerical value of a menu item needs to be changed (e.g. changing relay setpoint value) pressing the key will release the previous value to allow changing it. the far right digit will be flashing to signify that the setting has been released to be changed. Use or to change the value of that digit. Use to toggle to the next digit. When the proper value is set, press & to enter the new value.

5.2 Programming Code Descriptions

The following is a listing of each programming code for the DSF26 along with a description of its function. Diagram 5.2 shows a flow chart of the programming process:

- E0 - EbEne Programming mode enabled. Pressing will toggle through each of the 4 programming branches (see Diagram 5.2).
- E0 - rELAI1 Branch 1 for setting Relay 1 parameters. Use to move to the next programming branch. Use to move down through the Relay 1 branch and set the Relay 1 parameters of setpoint, hysteresis, and delay time.
- SPt1 XXXX Relay 1 activation setpoint. To adjust the setpoint value, press the key to release the previous setpoint value. the far right digit will be flashing to signify that the setting has been released to be changed. Use or to change the value of the flashing digit. Use to toggle to the next digit. When the setpoint value is set, press & to enter the new value.
- HYS1 XXXX Relay 1 hysteresis. Hysteresis is defined in this as the temperature setpoint where the relay de-activates. It is designed to allow for a temperature “deadband” between the relay activation and de-activation. To adjust the setpoint value, press the key to release the previous setpoint value. the far right digit will be flashing to signify that the setting has been released to be changed. Use or to change the value of the flashing digit. Use to toggle to the next digit. When the setpoint value is set, press & to enter the new value.

6.0 Maintenance

The DSF26 is an electronic device with no wear parts other than the relay contacts which if properly connected will last for several hundred thousand cycles. The only maintenance required on this device may be an occasional cleaning of the sensing port if a coating or dirty process media exists. A possible indication of a dirty sensing port would be a sluggish response to changes in process pressure.

Do NOT tamper with the electronics as this voids your warranty.

7.0 Need help with your DSF26?

Call one of our friendly engineers at 412-788-2830.

Caution

PLEASE READ THE FOLLOWING GENERAL FLOW METER / MONITOR WARNINGS BEFORE ATTEMPTING INSTALLATION OF YOUR NEW DEVICE. FAILURE TO HEED THE INFORMATION HEREIN MAY RESULT IN EQUIPMENT FAILURE AND POSSIBLE SUBSEQUENT PERSONAL INJURY.

- **User's Responsibility for Safety:** KOBOLD manufactures a wide range of process sensors and technologies. While each of these technologies are designed to operate in a wide variety of applications, it is the user's responsibility to select a technology that is appropriate for the application, to install it properly, to perform tests of the installed system, and to maintain all components. The failure to do so could result in property damage or serious injury.
- **Inspect instrument for damage upon arrival:** Cracked, fractured, bent or otherwise damaged instruments must not be put into use, since the device is weakened to an unknown extent. Refer to Section 5.0, Arrival of Damaged Equipment, for additional information.
- **Media and Chemical Compatibility:** The maximum tolerances of the device have been determined using water. If using other media, especially corrosive media, it is critically important that the user determine chemical compatibility with our instruments. KOBOLD Instruments Inc. cannot accept responsibility for failure and consequences resulting from use of media other than water.
- **Material Compatibility:** Make sure that the model which you have selected is chemically compatible with the application liquids. While the meter is liquid and spray resistant when installed properly, it is not designed to be immersed.
- **Proper Installation in Flow System:** Install the device in a fully supported position within your flow system. This avoids excessive stresses which may damage the instrument. In particular:
 - a.) Ensure that the plumbing leading to and from the instrument is fully supported and that the instrument does not perform the physical function of a joint.
 - b.) When calculating stress on the device caused by plumbing, the weight of the medium in the pipes must be considered as well.
 - c.) Misaligned runs of rigid piping can cause large stresses when connected to the instrument. Do not connect in such a fashion.
 - d.) When connecting fittings, hold the instrument fittings rigid with a correctly sized wrench. Do not install by twisting the instrument into the pipe fittings.
 - e.) Do NOT install by holding the device housing to provide counter-torque to the pipe fitting.
 - f.) Use an appropriate amount of PTFE tape on male threads of fitting. This reduces the twisting stresses produced by tightening the fittings into each other.
 - g.) Do not use pliers or wrenches on the housing, as this may damage it.

- h.) Do not overtighten, as this may fracture the fittings.
- **While Operating the Flow System:** During operation, there are a number of situations to avoid:
 - a.) The sudden cessation of fluid flow causes what is typically referred to as "water hammer". Most people are familiar with this phenomenon from their home experience - it is the cause behind the loud clank of water pipes which occurs when faucets are turned off too suddenly. The cause behind this "water hammer" is quite easy to visualize. Water is fairly massive. The amount of water in long runs of pipe is quite substantial. When the faucets are turned off suddenly, especially from a full on condition, the water has considerable momentum and does not want to stop flowing. The situation is similar to stopping a car by running into a wall, rather than by applying brakes. Both are sudden rather than gradual. The damage to the wall can be substantial (not to mention the car).
 - b.) The "water hammer" causes surges in fluid pressure which could cause the measurement instrument's pressure limit to be exceeded, resulting in failure and possible personal injury.
 - c.) Fluid surges, as well as the water hammer, can be particularly damaging to empty flowmeters since there is no back pressure in the device. The damage is caused, once again, by momentary excess pressure. To avoid these surges, fluid lines should remain full (if possible) and water flow should be introduced to the device slowly.
 - d.) If the instrument is isolated with inlet and outlet valves, the flowmeter must be completely drained when said valves are both closed. Failure to do so could result in damage to the device caused by thermal expansion of fluid.
 - e.) Freezing of water in the instrument must be avoided since the resultant expansion will damage the flowmeter and make it unsafe for use.
 - **Wiring and Electrical:** Section 2.0, Specifications and Section 3.0, Installation Instructions, provide the voltage and current limitations and the wiring for the various sensor types. The sensor electrical ratings should never be exceeded. Electrical wiring of the sensor should be performed in accordance with all applicable national, state and local codes.
 - **Temperature and Pressure:** Section 2.0, Specifications, provides the temperature and pressure limits for each model. Operation outside these limitations will cause damage to the unit and can potentially cause personal injury. Fluid should never be allowed to freeze inside the sensor.
 - **Make a Fail-safe System:** Design a fail-safe system that accommodates the possibility of switch or power failure. In critical applications, KOBOLD recommends the use of redundant backup systems and alarms in addition to the primary system.