

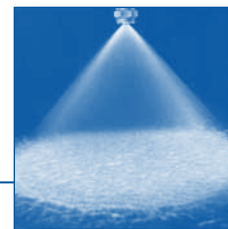

Full cone nozzles

Axial-flow large capacity

Series 403



These use a slot-type vane to handle larger volumes but still create uniform spray patterns over a wide pressure range.

Applications:

- Chemical reactors
- Surface spraying
- Cooling gaseous fluids and solids

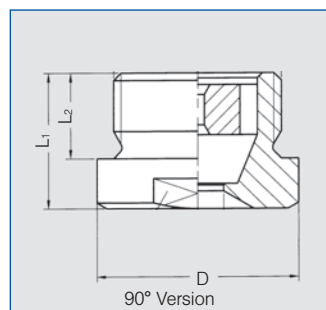

90° Version

Inlet (Male NPT)	Dimensions (in.)				Wt. (lb.)
	L1	L2	D	Flats	
2-1/2	2.0	1.1	3.3	3.0	2.9
3	2.4	1.2	3.9	3.3	3.7
3-1/2	2.8	1.3	4.6	4.1	8.4

120° Version

Inlet (Male NPT)	Dimensions (in.)				Wt. (lb.)
	L1	L2	D	Flats	
2-1/2	4.9	1.1	3.3	3.0	6.6
3	6.0	1.2	3.9	3.3	11.5
3-1/2	6.1	1.3	4.6	4.1	18.5
4	6.5	1.4	5.0	4.3	21.0

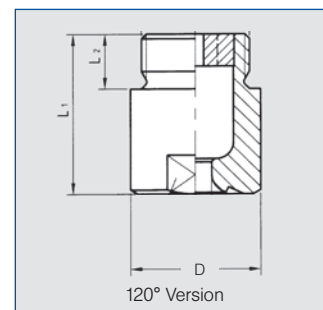

Full cone

Spray angle	Ordering no.		Orifice diam. (in.)	Free passage (in.)	Flow Rate (Gallons Per Minute)										Spray Diam. D (in.) @ 30 psi				
	Type	Mat. no. 316L SS 1Y			Connection Male NPT				liters per minute	2 bar	30 psi	40 psi	60 psi	80 psi	100 psi	H=20"	H=40"		
					2 1/2"	3"	3 1/2"	4"											
90°	403.446	○	BY	-	-	-	.985	.473	52	69	91	400	107	120	141	159	173	35	67
	403.486	○	BY	-	-	-	1.162	.473	65	86	114	500	134	150	177	198	217	35	67
	403.526	○	-	MA	-	-	1.000	.544	82	109	143	630	169	189	223	250	273	35	67
	403.606	○	-	-	MC	-	1.576	.591	131	173	228	1000	269	300	353	396	433	38	69
120°	403.448	○	BY	-	-	-	1.005	.394	52	69	91	400	107	120	141	159	173	59	112
	403.488	○	BY	-	-	-	1.162	.433	65	86	114	500	134	150	177	198	217	59	112
	403.528	○	-	MA	-	-	1.261	.591	82	109	143	630	169	189	223	250	273	59	112
	403.568	○	-	-	MC	-	1.497	.473	105	138	182	800	215	240	283	317	347	59	112
	403.608	○	-	-	MC	-	1.655	.473	131	173	228	1000	269	300	353	396	433	59	112
	403.628	○	-	-	-	ME	1.773	.591	163	216	285	1250	336	375	442	495	542	63	114

Example Type + Material no. + Conn. = Ordering no.
 for ordering: 403.448 + 1Y + BY = 403.448.1Y.BY