



## Flat fan nozzle tips with socket alignment flats, 3/4 inch Series 672 / 673



**Lechler flat fan tips with socket alignment flats offer the positive spray orientation of dovetail designs with key improvements.**

**Applications:**

- Roll cooling
- Roll bite lubrication
- Strip and roll cleaning

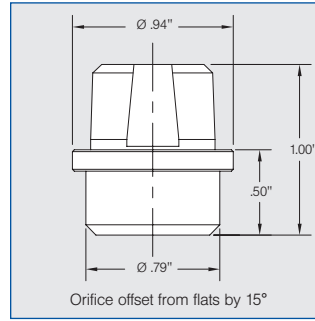

Theoretical Spray Width  
Actual width may vary.

Nozzle Angle	Width in inches (B)	
	H=10"	H=24"
15°	2.6	6.3
25°	4.4	10.6
40°	7.3	17.5
50°	9.3	22.4
80°	16.8	40.3
110°	28.5	68.5

Ordering no.						Equivalent Orifice diam. (in.)	Flow Rate (Gallons Per Minute)									
Type							Material no.			10 psi	20 psi	liters per minute 2 bar	40 psi	60 psi	80 psi	100 psi
Spray Angle							303 SS	316 SS	Brass							
15°	25°	40°	50°	80°	110°	16	17	30								
672. 641	672. 642	672. 643	672. 644	672. 646	672. 647	○	○	○	.099	.62	.88	4.00	1.24	1.52	1.75	1.96
672. 671	672. 672	672. 673	672. 674	672. 676	672. 677	○	○	○	.106	.74	1.04	4.75	1.47	1.80	2.08	2.33
672. 721	672. 722	672. 723	672. 724	672. 726	672. 727	○	○	○	.118	.98	1.38	6.30	1.95	2.39	2.76	3.09
672. 761	672. 762	672. 763	672. 764	672. 766	672. 767	○	○	○	.137	1.24	1.75	8.00	2.48	3.04	3.51	3.92
672. 801	672. 802	672. 803	672. 804	672. 806	672. 807	○	○	○	.157	1.55	2.19	10.0	3.10	3.80	4.39	4.90
672. 841	672. 842	672. 843	672. 844	672. 846	672. 847	○	○	○	.177	1.94	2.74	12.5	3.88	4.75	5.48	6.13
672. 881	672. 882	672. 883	672. 884	672. 886	672. 887	○	○	○	.197	2.48	3.51	16.0	4.96	6.08	7.02	7.85
672. 921	672. 922	672. 923	672. 924	672. 926	672. 927	○	○	○	.220	3.10	4.39	20.0	6.20	7.60	8.77	9.81
672. 961	672. 962	672. 963	672. 964	672. 966		○	○	○	.236	3.88	5.48	25.0	7.75	9.50	10.9	12.2
		673. 013	673. 014			○	-	-	.283	5.20	7.34	33.5	10.4	12.7	14.7	16.4
673. 041	673. 042	673. 043	673. 044	673. 046	673. 047	○	○	○	.315	6.20	8.77	40.0	12.4	15.2	17.5	19.6
		673. 083	673. 084			○	-	-	.354	7.75	10.9	50.0	15.5	18.9	21.9	24.5
673. 121	673. 122	673. 123	673. 124	673. 126	673. 127	○	○	○	.394	9.77	13.8	63.0	19.5	23.9	27.6	30.9

**Example** Type + Material no. = Ordering no.  
for ordering: 672. 721 + 16 = 672. 721. 16

**Series 672 bases, caps and accessories**

Ordering no. Type	Description	Material no.			
		Mild Steel 03	303 SS 16	316 SS 17	Brass 30
<b>Bases</b>					
067. 210. xx. 01	Weld Base, 1.06" long	○		○	
067. 210. xx. 02	Weld Base, 1.37" long	○		○	
067. 210. xx. 03	Weld Base, 1.67" long	○		○	
067. 211. xx. 04	Weld Base, 2.37" long	○		○	
067. 211. xx. 05	Weld Base, 4.31" long	○		○	
067. 216. xx. BK	Threaded, 3/4" NPT Male		○	○	○
<b>Caps</b>					
065. 600. xx. 00	Nozzle Tip Retainer Cap		○	○	○
<b>Accessories</b>					
006. 720. xx. 00	Nozzle Plug		○		

**Example** Type + Material no. (xx) = Ordering no.  
for ordering: 067. 210. xx. 01 + 17 = 067. 210. 17. 01

