

⚠ WARNING

To avoid unpredictable system behavior that can cause personal injury and property damage:

- Disconnect electrical supply (when necessary) before installation, servicing, or conversion.
- Disconnect air supply and depressurize all air lines connected to this product before installation, servicing, or conversion.
- Operate within the manufacturer's specified pressure, temperature, and other conditions listed in these instructions.
- Medium must be moisture-free if ambient temperature is below freezing.
- Service according to procedures listed in these instructions.
- Installation, service, and conversion of these products must be performed by knowledgeable personnel who understand how pneumatic products are to be applied.
- After installation, servicing, or conversion, air and electrical supplies (when necessary) should be connected and the product tested for proper function and leakage. If audible leakage is present, or the product does not operate properly, do not put into use.
- Warnings and specifications on the product should not be covered by paint, etc. If masking is not possible, contact your local representative for replacement labels.

⚠ WARNING

Product rupture can cause serious injury.
Do not connect regulator to bottled gas.
Do not exceed maximum primary pressure rating.

⚠ CAUTION

Polycarbonate bowls, being transparent and tough, are ideal for use with Filters and Lubricators. They are suitable for use in normal industrial environments, but should not be located in areas where they could be subjected to direct sunlight, an impact blow, nor temperatures outside of the rated range. As with most plastics, some chemicals can cause damage. Polycarbonate bowls should not be exposed to chlorinated hydrocarbons, ketones, esters and certain alcohols. They should not be used in air systems where compressors are lubricated with fire-resistant fluids such as phosphate ester and di-ester types.

Metal bowls are recommended where ambient and/or media conditions are not compatible with polycarbonate bowls. Metal bowls resist the action of most such solvents, but should not be used where strong acids or bases are present or in salt laden atmospheres. Consult the factory for specific recommendations where these conditions exist.

TO CLEAN POLYCARBONATE BOWLS USE MILD SOAP AND WATER ONLY! DO NOT use cleansing agents such as acetone, benzene, carbon tetrachloride, gasoline, toluene, etc., which are damaging to this plastic.

Bowl guards are recommended for added protection of polycarbonate bowls where chemical attack may occur.

Introduction

Follow these instructions when installing, operating, or servicing the product.

Application Limits

These products are intended for use in general purpose compressed air systems only.

Maximum Recommended Pressure Drop:

	kPa	PSIG	bar
Particulate Filter	70	10	0.7
Operating Pressure Maximum	kPa	PSIG	bar
Metal Bowl	2068	300	21
Metal Bowl with Sight Gauge	1724	250	17
Metal Bowl with Auto Drain	1207	175	12

Operating Temperature Range

Metal Bowl	4°C to 82°C (40°F to 180°F)
Metal Bowl with Sight Gauge	4°C to 66°C (40°F to 150°F)
Metal Bowl with Auto Drain	4°C to 49°C (40°F to 120°F)

Symbols

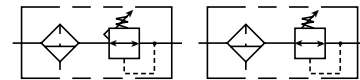

Filter / Regulator

Installation

Before installing, blow out pipe line to remove scale and other foreign matter. This unit has DRYSEAL pipe threads; use pipe compound or tape sparingly to MALE threads only. Always start compound or tape at least one thread back from small end of fitting. Install regulator on pipeline as near as possible to equipment serviced.

Adjustment

Unlock B11 by pushing down knob. Turn knob clockwise to increase the reduced pressure (regulated pressure), and counter-clockwise to lower pressure. On B12, unlock lock nut and turn Tee-handle same as described above. With relieving type regulators, the reduced pressure will follow adjustment of the knob. With non-relieving regulators, adjustment for lower reduced pressure will only be obtained after airflow is created or air is bled off.

When resetting or lowering reducing pressure, always drop below the desired setting and adjust up to setting needed.

⚠ WARNING

FAILURE OR IMPROPER SELECTION OR IMPROPER USE OF THE PRODUCTS AND/OR SYSTEMS DESCRIBED HEREIN OR RELATED ITEMS CAN CAUSE DEATH, PERSONAL INJURY AND PROPERTY DAMAGE.

This document and other information from The Company, its subsidiaries and authorized distributors provide product and/or system options for further investigation by users having technical expertise. It is important that you analyze all aspects of your application, including consequences of any failure and review the information concerning the product or systems in the current product catalog. Due to the variety of operating conditions and applications for these products or systems, the user, through its own analysis and testing, is solely responsible for making the final selection of the products and systems and assuring that all performance, safety and warning requirements of the application are met.

The products described herein, including without limitation, product features, specifications, designs, availability and pricing, are subject to change by The Company and its subsidiaries at any time without notice.

EXTRA COPIES OF THESE INSTRUCTIONS ARE AVAILABLE FOR INCLUSION IN EQUIPMENT / MAINTENANCE MANUALS THAT UTILIZE THESE PRODUCTS. CONTACT YOUR LOCAL REPRESENTATIVE.

Maintenance/Cleaning

Note: To clean integral filter/regulator, it is not necessary to remove the unit from the airline.

If the air filter element is kept fairly clean, or changed when a noticeable drop in pressure occurs, the regulator should provide long periods of uninterrupted service. Erratic regulator operation, or loss of regulation, is most always due to dirt (rust, pipe tape etc.) in the disc area. To clean, shut off and vent all air line pressure to the unit being cleaned. Before removing spring cage (B11), push down and turn adjusting knob counterclockwise until it stops; with (B12) turn until it comes out of the spring cage. Carefully remove spring cage and bowl. Remove filter element baffle and retainer. Wipe parts clean with soapy water or denatured alcohol. **Caution! Never use solvents like carbon tetrachloride, trichlorethylene, acetone, or paint thinner to clean any parts.** If using compressed air to blow dry, be sure to wear appropriate eye protection. When reassembling, refer to drawing as guide. Be sure stem fits into center area of diaphragm assembly and O-rings on disc are lubricated before installing filter element retainer. Torque spring cage and bowl before using (see illustration).

Service Kits / Parts Available

Description	Kit / Part Number
Adjusting Knob (In Kit CKR10Y)	R10Y54
Adjusting Spring (Control)	
“A” Range Spring, 0 – 25 PSI (0 – 1.7 bar)	SPR-387
“B” Range Spring, 0 – 60 PSI (0 – 4.1 bar)	SPR-388
“C” Range Spring, 0 – 125 PSI (0 – 8.5 bar)	SPR-389
“D” Range Spring, 0 – 250 PSI (0 – 17 bar)	SPR-390
Bottom Spring (Return)	SPR 391-1
Bowl O-Ring (In Bowl Replacement Kit)	
Standard	F10Y103-1
Viton	F10Y103-2VT
Bowl Replacement Kit (Bowl Gasket, Bowl, and Manual Drain)	
Zinc Bowl (D)	BKF11Y
Zinc Bowl w/Sight Gauge (W)	BKF11WY
Auto Drain Repair Kit * (All Seals, Float Assembly, Disc Assembly, and Strainer)	RK602MD
Filter Element Replacement Kit	
5 Micron	EKF10VY
40 Micron	EKF10Y
Element Retainer	F10Y49
Lower Baffle	F10Y76
Repair Kit (Diaphragm Assembly, Inner Valve, and Bowl O-Ring)	
Relieving *	RKR10Y
Non-Relieving *	RKR10KY
B11 Spring Cage Kit (Adjusting Screw, Spring Cage, Adjusting Knob)	CKR10Y
B12 Spring Cage Kit (Spring Cage, Lock Nut, T-Handle Assembly, Spring Button)	CKR11Y

* Add “X64” at end of Kit Number for Viton version (e.g., RKR10YX64).

Accessories

Gauges	
0 to 60 PSI (0 to 4 bar)	275Y60S
0 to 160 PSI (0 to 11 bar)	275Y160S
0 to 300 PSI (0 to 20 bar)	275Y300S
Mounting Bracket Kit	SAR10Y57
Panel Mount Bracket (In Kit SAR10Y57)	R10Y57
Panel Mount Nut (In Kit SAR10Y57)	
Plastic	R10X51-P
Aluminum	R10X51-A
Drain Kits	
Complete Auto Drain (Standard)	SA602MD
Complete Auto Drain (Viton)	SA602MDX64
Manual Drain Assembly (Standard)	SA600Y7-1
Manual Drain Assembly (Viton)	SA600Y7-1VT
Piston Drain (Complete)	4210

B11

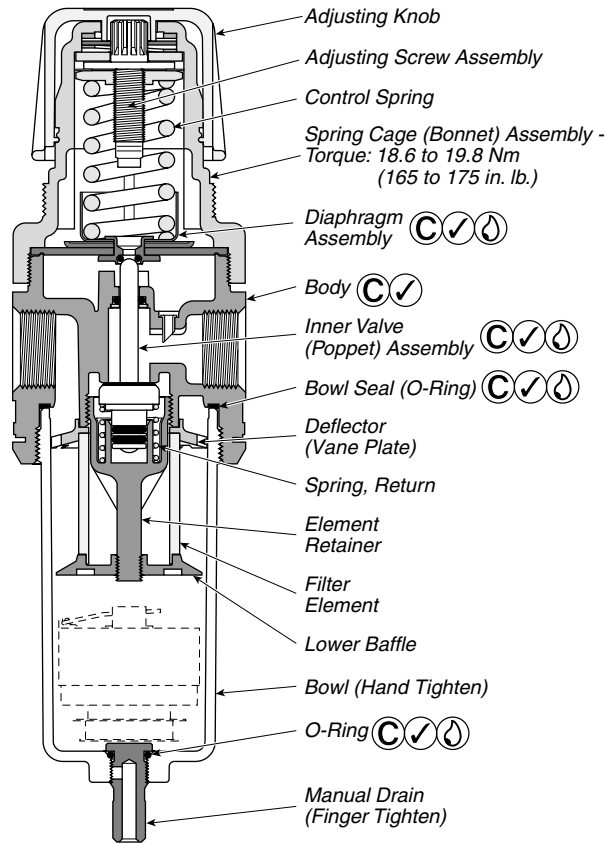

- (D) Lightly grease with provided lubricant.
- (✓) Inspect for nicks, scratches, and surface imperfections. If present, reduced service life is probable and future replacement should be planned.
- (C) Clean with lint-free cloth.

B12

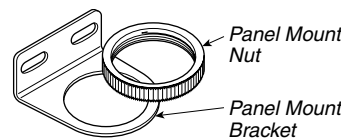
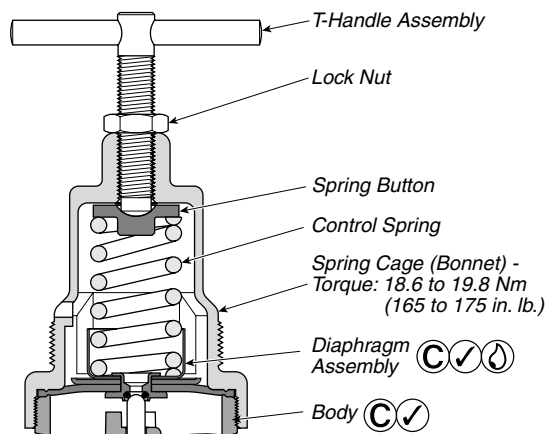

SAR10Y57 Panel Mount Bracket Kit