

a	Manway	17"
b	Outlet	1.5" Tri-Clamp
c	CIP	1.5" Tri-Clamp
d	Whirlpool Inlet	1.5" Tri-Clamp
e	Drain	1.5" Tri-Clamp
f	Thermocouple Port	1.5" Tri-Clamp
g		
h	Vent	
i	Condensate Drain	Pipe
j	Burner Exhaust	
k	Burner Port	4" Flange
h	Chimmney	8"
m	Clean-Out	

Dimensions: 6'6" height 3'9" Diameter, Weight 1200 Lbs.
 Power Requirements: Natrual Gas Line
 Total Brew House 208-240V 3 Phase 30 Amps.

Vessel Specifications			
	Unit	Container	Jacket
Working Pressure	PSI		
Tested Pressure	PSI		
Termerature Range	F	15-260	
Material		SS304	SS304
Full Volume	BBL		
Rated Volume	BBL	5	

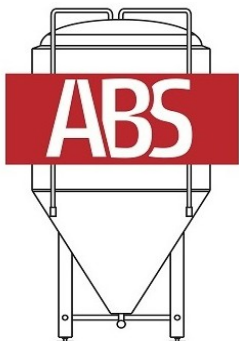
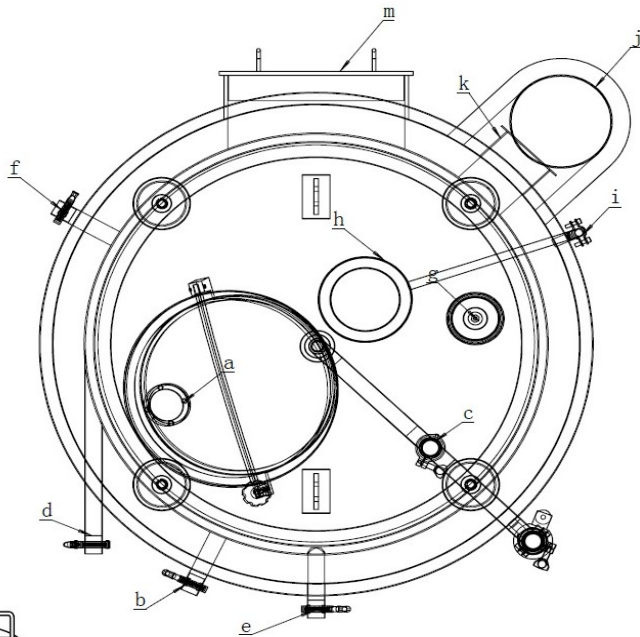
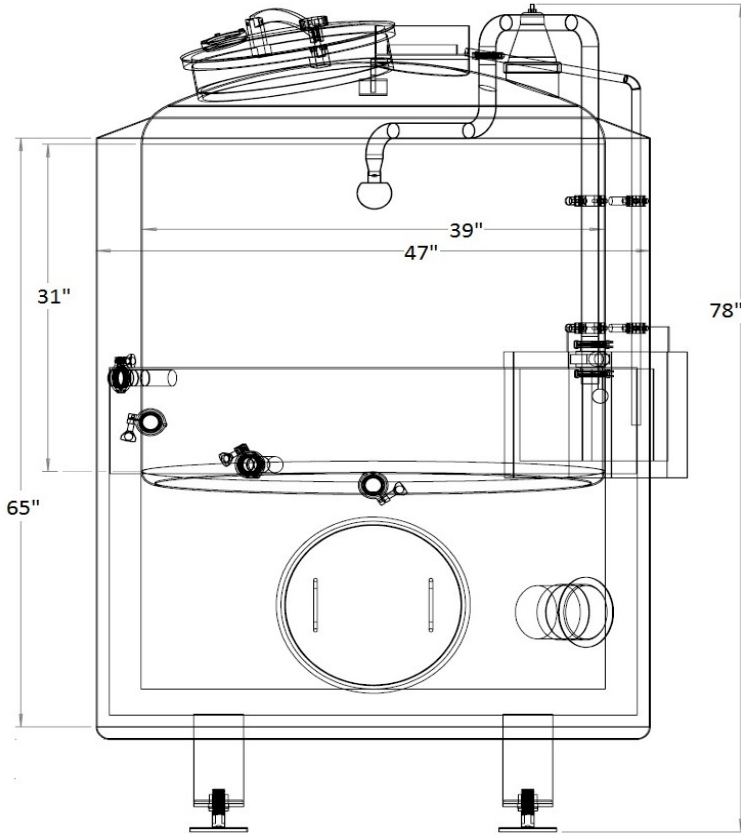

Atlantic Brew Supply
 5 Barrel Direct Fired Kettle/Whirlpool
 Model: KW5BBLDF