

a	Manway	17"
b	Outlet	1.5" Tri-Clamp
c	Inlet	1.5" Tri-Clamp
d	CIP	1.5" Tri-Clamp
e	Whirlpool Inlet	1.5" Tri-Clamp
f	Bottom Drain	1.5" Tri-Clamp
g	Thermocouple Port	1.5" Tri-Clamp 1/2" FNPT
h	Chimney	8"
i	Condensate Drain	Pipe
j	Steam Ports	3/4" FNPT

Dimensions: 8'5" height 6'1" Diameter, Weight 1400 Lbs.  
 Power Requirements: Power is supplied from the Brew House control panel. Total Brew House 208-240V 3 Phase 30 Amps.

Vessel Specifications			
	Unit	Container	Jacket
Working Pressure	PSI		45
Tested Pressure	PSI		90
Temperature Range	F	15-260	15-260
Material		SS304	SS304
Full Volume	BBL		
Rated Volume	BBL	20	
Insulation Material		Polyurethane Foam	
Insulation Thickness	Inch	3 1/4"	
Heat/Cold Transfer Area	Sqf.		
PRV Actuation	PSI		
Glycol Volume	Gal.		

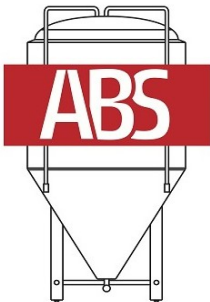
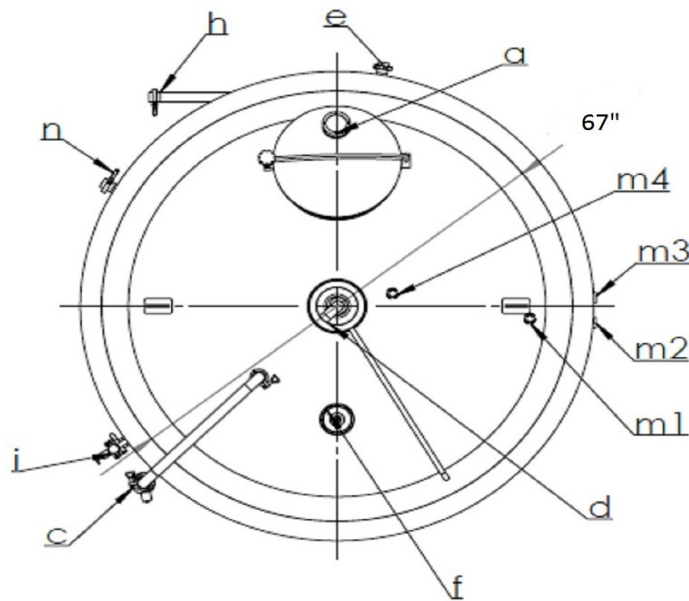

**Atlantic Brew Supply**  
 20 Barrel Kettle/Whirlpool  
 Model: KW20BBL