

a	Manway	17"
b	Carbonation Stone	1.5" Tri-Clamp
c	CIP	1.5" Tri-Clamp
d	Pressure Gauge	1.5" Tri-Clamp
e	Racking Arm	1.5" Tri-Clamp
f	Bottom Drain	1.5" Tri-Clamp
g	Temperature Gauge	1.5" Tri-Clamp
h	PRV	1.5" Tri-Clamp
i	Hop Port	4" Tri-Clamp
j	Sample Valve	1.5" Tri-Clamp
K1-2	Thermocouple Port	1.5" Tri-Clamp 1/2" FNPT
r	Blow-off arm	1.5" Tri-Clamp
m1-4	Steam Ports	3/4" FNPT

Dimensions: 6'6" height 3'2" Diameter, Weight 600 Lbs.  
 Power Requirements: None  
 Fermenter Control Panel Supplies 24VDC to Glycol Valve

### Vessel Specifications

	Unit	Container	Jacket
Working Pressure	PSI	15	45
Tested Pressure	PSI	30	90
Temperature Range	F	15-220	15-220
Material		SS304	SS304
Full Volume	BBL	4.11	
Rated Volume	BBL	3	
Insulation Material		Polyurethane Foam	
Insulation Thickness	Inch	3 1/4"	
Heat/Cold Transfer Area	Sqf.		
PRV Actuation	PSI	15	
Glycol Volume	Gal.		2

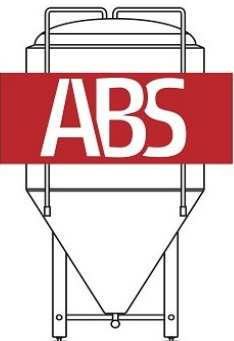
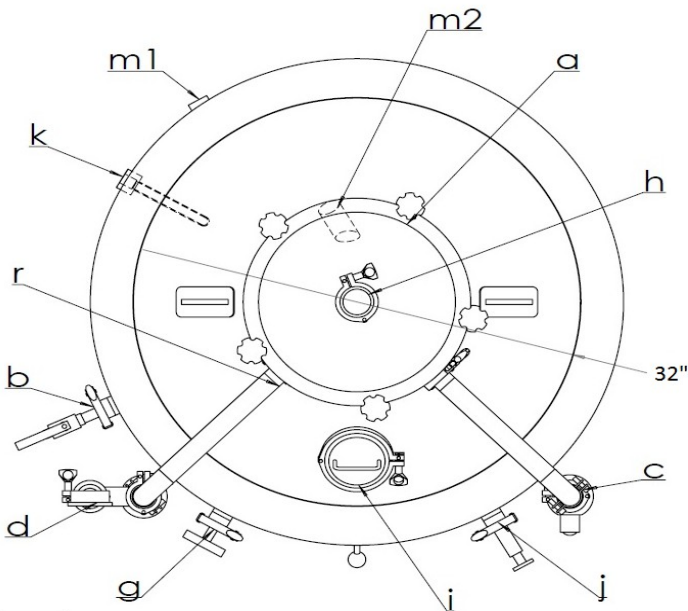

**Atlantic Brew Supply**

3 Barrel Fermenter Top Manway

Model: FV3BBLTM