

ABS-Commercial

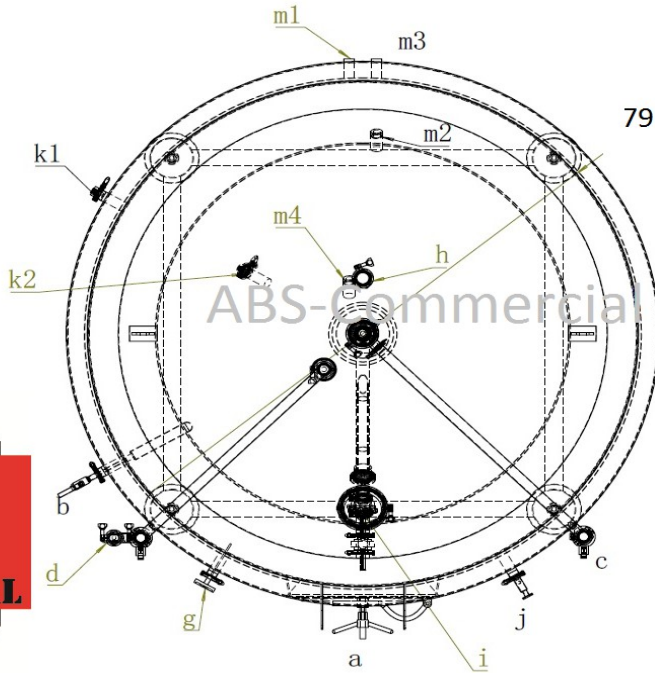

ABS-Commercial

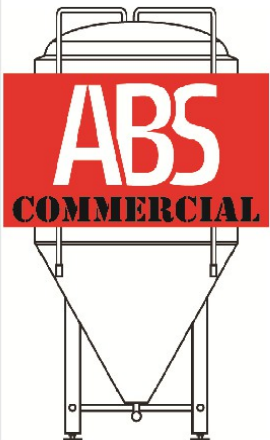

ABS-Commercial		
3709 Neil Street Raleigh, NC 27607 (919) 400-9087		
a	Manway	580x480x133
b	Carbonation Port	1.5" Tri-Clamp
c	CIP	1.5" Tri-Clamp
d	Pressure Gauge	1.5" Tri-Clamp
e	Racking Arm	50mm DIN
f	Bottom Drain	1.5" Tri-Clamp
g	Temperature Gauge	1.5" Tri-Clamp
h	PRV	1.5" Tri-Clamp
i	Hop Port	4" Tri Clamp
j	Sample Valve	1.5" Tri-Clamp
K1-2	Thermocouple Ports	0.5" FNPT
r	Blow Off Arm	1.5" Tri-Clamp
M1-4	Glycol Ports	1.00" FNPT
Dimensions: 14'10" Height 7'5" Width 1800 Weight		
Power Requirements: None		
Fermenter Control Panel Supplies Power to Glycol Solenoid		

Vessel Specifications			
	Units	Container	Jacket
Working Pressure	PSI	15	
Tested Pressure	PSI	30	30
Temperature Range	F	15-220	15-220
Material		SS304	SS304
Full Volume	BBL	72	
Rated Volume	BBL	60	
Insulation Material	Polyurethane Foam		
Insulation Thickness	Inch	3 1/4"	
Heat/Cold Transfer Area	sqf.		
PRV Actuation	PSI	15	
Glycol Volume	Gal.		24



**ABS-COMMERCIAL**  
**60 BARREL FERMENTER**  
**MODEL: FV60BBL**