

SUR-PAK™ POUCH DISPENSER

SP-4D



SUR-PAK™ POUCH DISPENSER

SP-4D TECHNICAL SPECIFICATION

Solid Models Available Online

The SP-4D pouch dispenser is designed for ease of use and reliability. The sachets or pouches can be either in roll form or in continuous bandolier format. The unit is self-threading and will feed, cut, and place the pouches directly into your product or packaging line. It dispenses pouches up to 89 mm/3.5" wide and 6 mm/0.25" thick at speeds of up to 100 pouches per minute. A color touchscreen makes setting up operations and monitoring the unit easy. It comes on an adjustable height stand with castors for easy integration into packaging lines; just roll it up to your line and a trigger eye will automatically dispense the product or a signal from your packaging line can make this unit a slave to your process. Having a dual tractor drive system increases reliability, ensuring constant contact with the product at all times without crushing or damaging the product.

Easy to use, simply roll the SP-4D dispenser up to your line, plug the unit into a 110 V AC or 220 V AC outlet, connect to an air supply and you are ready to go. Changeovers do not require any tools.

BENEFITS

- Self-teach optics
- Self-threading
- Tool-less product changeover in under 5 minutes

SPECIFICATIONS

- Waffle grip belt system - grips material on both sides
- 2-phase stepper
- Power requirements: 110 V AC or 220 V AC, 5 amps
- 90 psi (6 bar) compressed air
- Cycle rate: 100 cuts per minute

OPTIONS

- Allen Bradley controls
- Bottle handling systems
- All electric system, pneumatic free
- Servo drive system
- Enclosure
- Clean room or wash down models

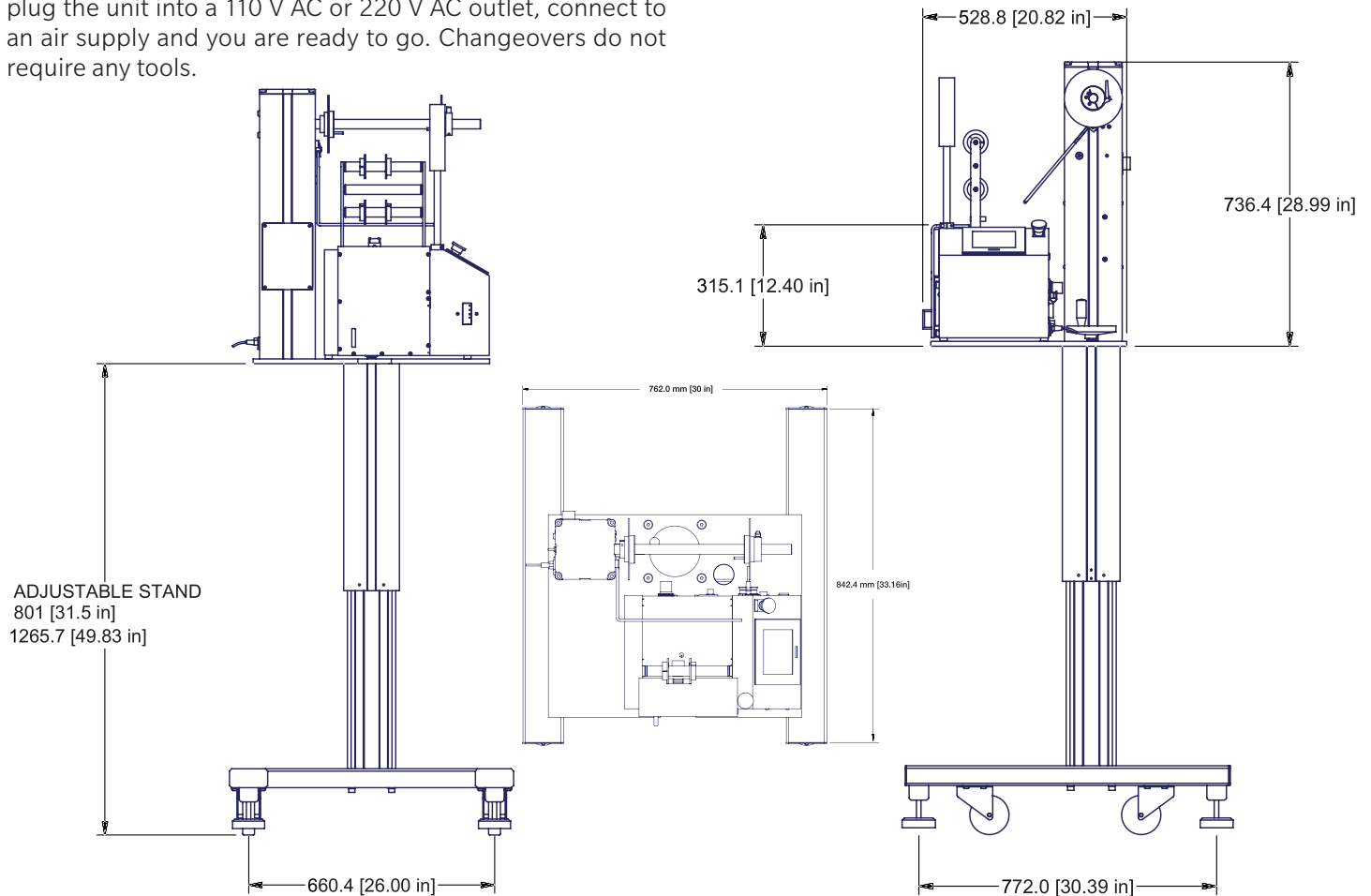

WARNING:

EQUIPMENT MUST BE GUARDED IN ACCORDANCE WITH ALL FEDERAL, STATE, AND LOCAL REQUIREMENTS



visit us online!



FOR ALL YOUR FEEDING AND CUTTING NEEDS

26 Just Road, Fairfield, NJ, 07004 | 973-439-1428 | azcocorp.com